

Programming Guide
Dynamic Measurement DC Source
Agilent Models 66312A, 66332A
System DC Power Supply
Agilent Models 6631B, 6632B, 6633B, 6634B
6611C, 6612C, 6613C, 6614C



Agilent Technologies
Innovating the HP Way

Agilent Part No. 5962-8198
Microfiche No 5962-8199

Printed in U.S.A.
January, 2000

Safety Guidelines

The beginning of the Operating Guide has a Safety Summary page. Be sure you are familiar with the information on this page before programming the dc source for operation from a controller.

Printing History

The edition and current revision of this manual are indicated below. Reprints of this guide containing minor corrections and updates may have the same printing date. Revised editions are identified by a new printing date. A revised edition incorporates all new or corrected material since the previous printing date. Changes to the manual occurring between revisions are covered by change sheets shipped with the guide.

This document contains proprietary information protected by copyright. All rights are reserved. No part of this document may be photocopied, reproduced, or translated into another language without the prior consent of Agilent Technologies. The information contained in this document is subject to change without notice.

Table of Contents

Safety Guidelines	2
Printing History	2
Table of Contents	3
1 - GENERAL INFORMATION	7
About this Guide	7
Documentation Summary	7
External References	8
GPIB References	8
SCPI References	8
2 - INTRODUCTION TO PROGRAMMING	9
VXIplug&play Power Products Instrument Drivers	9
Supported Applications	9
System Requirements	9
Downloading and Installing the Driver	9
Accessing Online Help	10
GPIB Capabilities of the DC Source	10
GPIB Address	10
RS-232 Capabilities of the DC Source	10
RS-232 Data Format	10
RS-232 Flow Control	11
RS-232 Programming Example	11
RS-232 Troubleshooting	12
Introduction to SCPI	12
Conventions Used in This Guide	12
Types of SCPI Commands	13
Multiple Commands in a Message	13
Moving Among Subsystems	14
Including Common Commands	14
Using Queries	14
Types of SCPI Messages	14
The Message Unit	15
Headers	15
Query Indicator	15
Message Unit Separator	15
Root Specifier	15
Message Terminator	15
SCPI Data Formats	16
Numerical Data Formats	16
Suffixes and Multipliers	16
Response Data Types	16
SCPI Command Completion	17
Using Device Clear	17
3 - PROGRAMMING THE DC SOURCE	19
Introduction	19
Programming the Output	19
Power-on Initialization	19
Enabling the Output	19
Output Voltage	20
Output Current	20
Triggering Output Changes	21
SCPI Triggering Nomenclature	21

Output Trigger System Model	21
Setting the Voltage or Current Trigger Levels	21
Initiating the Output Trigger System	22
Generating Triggers	22
Making Measurements	23
Voltage and Current Measurements	23
Internally Triggered Measurements	25
SCPI Triggering Nomenclature	25
Measurement Trigger System Model	25
Initiating the Measurement Trigger System (Agilent 66312A, 66332A Only)	25
Selecting the Measurement Trigger Source (Agilent 66312A, 66332A Only)	26
Generating Measurement Triggers (Agilent 66312A, 66332A Only)	26
Measuring Output Pulses (Agilent 66312A, 66332A Only)	28
Current Detector	28
Pulse Measurement Queries	28
Controlling Measurement Samples	29
Varying the Voltage or Current Sampling Rate	29
Multiple Measurements (Agilent 66312A, 66332A Only)	29
Pre-event and Post-event Triggering (Agilent 66312A, 66332A Only)	30
Pulse Measurement Example (Agilent 66312A, 66332A only)	30
Programming the Status Registers	32
Power-On Conditions	32
Operation Status Group	33
Questionable Status Group	34
Standard Event Status Group	34
Status Byte Register	34
Determining the Cause of a Service Interrupt	35
Servicing Operation Status and Questionable Status Events	35
Monitoring Both Phases of a Status Transition	36
Inhibit/Fault Indicator	36
Remote Inhibit (RI)	36
Discrete Fault Indicator (DFI)	36
Using the Inhibit/Fault Port as a Digital I/O	37
DFI Programming Example	37
4 - LANGUAGE DICTIONARY	39
Introduction	39
Subsystem Commands	39
Common Commands	43
Programming Parameters	43
Calibration Commands	44
CALibrate:CURRent	44
CALibrate:CURRent:NEGative	44
CALibrate:CURRent:MEASure:LOWRange	44
CALibrate:CURRent:MEASure:AC	44
CALibrate:DATA	45
CALibrate:LEVel	45
CALibrate:PASSword	45
CALibrate:SAVE	45
CALibrate:STATe	46
CALibrate:VOLTagE	46
CALibrate:VOLTagE:PROTection	46
Measurement Commands	47
MEASure:ARRay:CURRent? FETCh:ARRay:CURRent?	47
MEASure:ARRay:VOLTagE? FETCh:ARRay:VOLTagE?	47

MEASure:CURRent? FETCh:CURRent?	48
MEASure:CURRent:ACDC? FETCh:CURRent:ACDC?	48
MEASure:CURRent:HIGH? FETCh:CURRent:HIGH?	48
MEASure:CURRent:LOW? FETCh:CURRent:LOW?	49
MEASure:CURRent:MAXimum? FETCh:CURRent: MAXimum?	49
MEASure:CURRent:MINimum? FETCh:CURRent:MINimum?	49
MEASure:VOLTage? FETCh:VOLTage?	50
MEASure:VOLTage:ACDC? FETCh:VOLTage:ACDC?	50
MEASure:VOLTage:HIGH? FETCh:VOLTage:HIGH?	50
MEASure:VOLTage:LOW? FETCh:VOLTage:LOW?	51
MEASure:VOLTage:MAXimum? FETCh:VOLTage:MAXimum?	51
MEASure:VOLTage:MINimum? FETCh:VOLTage:MINimum?	51
SENSe:CURRent:RANge	52
SENSe:CURRent:DETEctor	52
SENSe:FUNCTion	53
SENSe:SWEEp:OFFSet:POINts	53
SENSe:SWEEp:POINts	53
SENSe:SWEEp:TINterval	53
SENSe:WINDow	54
Output Commands	55
OUTPut	55
OUTPut:DFI	55
OUTPut:DFI:SOURce	55
OUTPut:PON:STATe	56
OUTPut:PROTEction:CLEar	56
OUTPut:PROTEction:DELAy	56
OUTPut:RELAy	57
OUTPut:RELAy:POLarity	57
OUTPut:RI:MODE	57
[SOURce:]CURRent	58
[SOURce:]CURRent:TRIGger	58
[SOURce:]CURRent:PROTEction:STATe	58
[SOURce:]DIGital:DATA	59
[SOURce:]DIGital:FUNCTion	59
[SOURce:]VOLTage:ALC:BWIDth? [SOURce:]VOLTage:ALC:BWIDth?	60
[SOURce:]VOLTage:TRIGger	60
[SOURce:]VOLTage:PROTEction	60
Status Commands	61
STATus:PRESet	61
STATus:OPERation?	61
STATus:OPERation:CONDition?	61
STATus:OPERation:ENABLe	62
STATus:OPERation:NTR STATus:OPERation:PTR	62
STATus:QUESTionable?	63
STATus:QUESTionable:CONDition?	63
STATus:QUESTionable:ENABLe	63
STATus:QUESTionable:NTR STATus:QUESTionable:PTR	64
*CLS	64
*ESE	65
*ESR?	65
*OPC	65
*PSC	66
*SRE	66
*STB?	67
*WAI	67

System Commands	68
DISPlay	68
DISPlay:MODE	68
DISPlay:TEXT	68
SYSTem:ERRor?	69
SYSTem:LANGUage	69
SYSTem:VERSion?	69
SYSTem:LOCal	70
SYSTem:REMote	70
SYSTem:RWLock	70
*IDN?	70
*OPT?	71
*RCL	71
*RST	71
*SAV	72
*TST?	72
Trigger Commands	73
ABORt	73
INITiate:SEQuence INITiate:NAME	73
INITiate:CONTinuous:SEQuence1 INITiate:CONTinuous:NAME	73
TRIGger	74
TRIGger:SOURce	74
TRIGger:SEQuence2 TRIGger:ACQuire	74
TRIGger:SEQuence2:COUNT:CURRent TRIGger:ACQuire:COUNT:CURRent	75
TRIGger:SEQuence2:COUNT:VOLTage TRIGger:ACQuire:COUNT:VOLTage	75
TRIGger:SEQuence2:HYSTeresis:CURRent TRIGger:ACQuire:HYSTeresis:CURRent	76
TRIGger:SEQuence2:HYSTeresis:VOLTage TRIGger:ACQuire:HYSTeresis:VOLTage	76
TRIGger:SEQuence2:LEVel:CURRent TRIGger:ACQuire:LEVel:CURRent	77
TRIGger:SEQuence2:LEVel:VOLTage TRIGger:ACQuire:LEVel:VOLTage	77
TRIGger:SEQuence2:SLOPe:CURRent TRIGger:ACQuire:SLOPe:CURRent	78
TRIGger:SEQuence2:SLOPe:VOLTage TRIGger:ACQuire:SLOPe:VOLTage	78
TRIGger:SEQuence2:SOURce TRIGger:ACQuire:SOURce	79
TRIGger:SEQuence1:DEFine TRIGger:SEQuence2:DEFine	79
*TRG	79
A - SCPI CONFORMANCE INFORMATION	81
SCPI Version	81
SCPI Confirmed Commands	81
Non-SCPI Commands	81
B - COMPATIBILITY LANGUAGE	83
Introduction	83
C - ERROR MESSAGES	89
Error Number List	89
D - EXAMPLE PROGRAMS	93
Introduction	93
Assigning the GPIB Address in Programs	93
Types of DOS Drivers	93
Error Handling	94
BASIC Controllers	94
Example 1. HP Vectra PC Controller Using Agilent 82335 Interface	94
Example 2. IBM Controller Using National Interface	96
Example 3. Controller Using BASIC	98
INDEX	99

General Information

About this Guide

This guide provides remote programming information for the following series of GPIB programmable dc power supplies:

- Agilent 66312A
- Agilent 66332A
- Agilent 6631B/6632B/6633B/6634B
- Agilent 6611C/6612C/6613C/6614C

You will find the following information in the rest of this guide:

- Chapter 1 Introduction to this guide.
- Chapter 2 Introduction to SCPI messages structure, syntax, and data formats. Examples of SCPI programs
- Chapter 3 Introduction to Programming the dc source with SCPI commands.
- Chapter 4 Dictionary of SCPI commands.
- Appendix A SCPI conformance information.
- Appendix B Use of the alternate Comptibility programming language.
- Appendix C Error messages

Documentation Summary

The following documents that are related to this Programming Guide have additional helpful information for using the dc source.

- ◆ User's Guide for Agilent 66312A and Agilent 6611C/6612C/6613C/3314C. Includes specifications and supplemental characteristics, how to use the front panel, how to connect to the instrument, and calibration procedures.
- ◆ User's Guide for Agilent 66332A and Agilent 6631B/6632B/6633B/6634B. Includes specifications and supplemental characteristics, how to use the front panel, how to connect to the instrument, and calibration procedures.

External References

GPIB References

The most important GPIB documents are your controller programming manuals - BASIC, GPIB Command Library for MS DOS, etc. Refer to these for all non-SCPI commands (for example: Local Lockout).

The following are two formal documents concerning the GPIB interface:

- ◆ *ANSI/IEEE Std. 488.1-1987 IEEE Standard Digital Interface for Programmable Instrumentation*. Defines the technical details of the GPIB interface. While much of the information is beyond the need of most programmers, it can serve to clarify terms used in this guide and in related documents.
- ◆ *ANSI/IEEE Std. 488.2-1987 IEEE Standard Codes, Formats, Protocols, and Common Commands*. Recommended as a reference only if you intend to do fairly sophisticated programming. Helpful for finding precise definitions of certain types of SCPI message formats, data types, or common commands.

The above two documents are available from the IEEE (Institute of Electrical and Electronics Engineers), 345 East 47th Street, New York, NY 10017, USA. The WEB address is www.ieee.org.

SCPI References

The following documents will assist you with programming in SCPI:

- ◆ *Standard Commands for Programmable Instruments Volume 1, Syntax and Style*
- ◆ *Standard Commands for Programmable Instruments Volume 2, Command References*
- ◆ *Standard Commands for Programmable Instruments Volume 3, Data Interchange Format*
- ◆ *Standard Commands for Programmable Instruments Volume 4, Instrument Classes*

To obtain a copy of the above documents, contact: Fred Bode, Executive Director, SCPI Consortium, 8380 Hercules Drive, Suite P3, Ls Mesa, CA 91942, USA

Introduction to Programming

VXIplug&play Power Products Instrument Drivers

VXIplug&play instrument drivers for Microsoft Windows 95 and Windows NT are now available on the Web at <http://www.agilent.com/find/drivers>. These instrument drivers provide a high-level programming interface to your Agilent Technologies instrument. VXIplug&play instrument drivers are an alternative to programming your instrument with SCPI command strings. Because the instrument driver's function calls work together on top of the VISA I/O library, a single instrument driver can be used with multiple application environments.

Supported Applications

- Agilent VEE
- Microsoft Visual BASIC
- Microsoft Visual C/C++
- Borland C/C++
- National Instruments LabVIEW
- National Instruments LabWindows/CVI

System Requirements

The VXIplug&play Power Products instrument driver complies with the following:

- Microsoft Windows 95
- Microsoft Windows NT 4.0
- HP VISA revision F.01.02
- National Instruments VISA 1.1

Downloading and Installing the Driver

NOTE: Before installing the VXIplug&play instrument driver, make sure that you have one of the supported applications installed and running on your computer.

1. Access Agilent Technologies' Web site at <http://www.agilent.com/find/drivers>.
2. Select the instrument for which you need the driver.
3. Click on the driver, either Windows 95 or Windows NT, and download the executable file to your pc.
4. Locate the file that you downloaded from the Web. From the **Start** menu select **Run** <path>\agxxxx.exe - where <path> is the directory path where the file is located, and agxxxx is the instrument driver that you downloaded .
5. Follow the directions on the screen to install the software. The default installation selections will work in most cases. The readme.txt file contains product updates or corrections that are not documented in the on-line help. If you decide to install this file, use any text editor to open and read it.

2 - Introduction to Programming

6. To use the *VXIplug&play* instrument driver, follow the directions in the *VXIplug&play* online help under "Introduction to Programming".

Accessing Online Help

A comprehensive online programming reference is provided with the driver. It describes how to get started using the instrument driver with Agilent VEE, LabVIEW, and LabWindows. It includes complete descriptions of all function calls as well as example programs in C/C++ and Visual BASIC.

- To access the online help when you have chosen the default Vxipnp start folder, click on the Start button and select Programs | Vxipnp | Agxxxx Help (32-bit).
- where agxxxx is the instrument driver.

GPIO Capabilities of the DC Source

All dc source functions except for setting the GPIO address are programmable over the GPIO. The IEEE 488.2 capabilities of the dc source are listed in the Specifications Table of the User's Guide.

GPIO Address

The dc source operates from an GPIO address that is set from the front panel. To set the GPIO address, press the **Address** key on the front panel and enter the address using the Entry keys. The GPIO address is stored in non-volatile memory.

RS-232 Capabilities of the DC Source

The dc source provides an RS-232 programming interface, which is activated by commands located under the front panel **Address** key. All SCPI and COMPAtibility commands are available through RS-232 programming. When the RS-232 interface is selected, the GPIO interface is disabled.

The EIA RS-232 Standard defines the interconnections between Data Terminal Equipment (DTE) and Data Communications Equipment (DCE). The dc source is designed to be a DTE. It can be connected to another DTE such as a PC COM port through a null modem cable.

NOTE: The RS-232 settings in your program must match the settings specified in the front panel Address menu. Press the front panel Address key if you need to change the settings.

RS-232 Data Format

The RS-232 data is a 10-bit word with one start bit and one stop bit. The number of start and stop bits is not programmable. However, the following parity options are selectable using the front panel Address key:

EVEN	Seven data bits with even parity
ODD	Seven data bits with odd parity
MARK	Seven data bits with mark parity (parity is always true)
SPACE	Seven data bits with space parity (parity is always false)
NONE	Eight data bits without parity

Parity options are stored in non-volatile memory.

Baud Rate

The front panel Address key lets you select one of the following baud rates, which is stored in non-volatile memory:

300 600 1200 2400 4800 9600

RS-232 Flow Control

The RS-232 interface supports several flow control options that are selected using the front panel Address key. For each case, the dc source will send a maximum of five characters after holdoff is asserted by the controller. The dc source is capable of receiving as many as fifteen additional characters after it asserts holdoff.

XON-XOFF	A software handshake that uses the ASCII control code DC3 (decimal code 19) to assert hold-off, and control code DC1 (decimal code 17) to release hold-off.
RTS-CTS	The dc source asserts its Request to Send (RTS) line to signal hold-off when its input buffer is almost full, and it interprets its Clear to Send (CTS) line as a hold-off signal from the controller.
DTR-DSR	The dc source asserts its Data Terminal Ready (DTR) line to signal hold-off when its input buffer is almost full, and it interprets its Data Set Ready (DSR) line as a hold-off signal from the controller.
NONE	There is no flow control.

Flow control options are stored in non-volatile memory.

RS-232 Programming Example

The following program illustrates how to program the power supply using RS-232 to set the output voltage and current and to readback the model number and output voltage. The program was written to run on any controller using Microsoft QBasic.

NOTE: The power supply must be configured for RS232 and the same baud rate and parity as the controller.

```

\ Program to write and read via RS232.
\ Configure the power supply for 9600 baud, even parity and RS232
\ Configure serial port for:
\   9600 baud
\   7 bit data
\   2 stop bits
\   Ignore request to send
\   Ignore carrier detect
\   Even parity           \ Needed with Vectra basic, ignored with QBasic
\   Send line feed
\   Reserve 1000 character buffer for serial I/O
\
DECLARE FUNCTION gets$ ()
CLS           \ Clears screen
LOCATE 1, 1   \ Position cursor at top left
\ Configure Com Port
OPEN "com1:9600,e,7,2,rs,cd,pe,lf" FOR RANDOM AS #1 LEN = 1000
PRINT #1, "OUTPUT ON"   \ Turn on output then set voltage and current
PRINT #1, "VOLT 6"      \ Set voltage to 6 volts
PRINT #1, "CURR .5"     \ Set current to 0.5 amps
PRINT #1, "*IDN?"       \ Query the power supply identification string
PRINT gets$             \ Go to gets$ Function and print data returned
PRINT #1, MEAS"VOLT?"; volt \ Query the power supply voltage
Volt = VAL (gets$)      \ Convert gets$ string to a value
PRINT gets$             \ Print the value of the voltage
END                     \ End of main program

```

2 - Introduction to Programming

```
FUNCTION gets$                                ` Get a new line feed terminated string from device #1
C$ = ""                                       ` Set C$ to null
WHILE c$ <> CHR$ (10)                          ` Set loop to stop at Line Feed
    C$ = INPUT$ (1, #1)                       ` Read 1 bit into file #1
    Resp$ = resp$ + c$                       ` Concatenate bit with previous bits
WEND                                           ` End of WHILE loop
gets$ = resp$                                 ` Assign response to gets$
END FUNCTION
```

RS-232 Troubleshooting

If you are having trouble communicating over the RS-232 interface, check the following:

- ◆ The computer and the dc source must be configured for the same baud rate, parity, number of data bits, and flow control options. Note that the dc source is configured for 1 start bit and 1 stop bit (these values are fixed).
- ◆ The correct interface cables or adaptors must be used, as described under RS-232 Connector. Note that even if the cable has the proper connectors for your system, the internal wiring may be incorrect.
- ◆ The interface cable must be connected to the correct serial port on your computer (COM1, COM2, etc.).

Introduction to SCPI

SCPI (Standard Commands for Programmable Instruments) is a programming language for controlling instrument functions over the GPIB. SCPI is layered on top of the hardware-portion of IEEE 488.2. The same SCPI commands and parameters control the same functions in different classes of instruments. For example, you would use the same DISPlay command to control the dc source display and the display of a SCPI-compatible multimeter.

Conventions Used in This Guide

Angle brackets	< >	Items within angle brackets are parameter abbreviations. For example, <NR1> indicates a specific form of numerical data.
Vertical bar		Vertical bars separate alternative parameters. For example, NORM TEXT indicates that either "TEXT" or "NORM" can be used as a parameter.
Square Brackets	[]	Items within square brackets are optional. The representation [SOURce:] VOLTage means that SOURce: may be omitted.
Braces	{ }	Braces indicate parameters that may be repeated zero or more times. It is used especially for showing arrays. The notation <A>{<,B>} shows that parameter "A" must be entered, while parameter "B" may be omitted or may be entered one or more times.
Boldface font		Boldface font is used to emphasize syntax in command definitions. TRIGger:COUNT:CURRent <NRf> shows command definition.
Computer font		Computer font is used to show program lines in text. TRIGger:COUNT:CURRent 10 shows a program line.

Types of SCPI Commands

SCPI has two types of commands, common and subsystem.

- ◆ Common commands generally are not related to specific operation but to controlling overall dc source functions, such as reset, status, and synchronization. All common commands consist of a three-letter mnemonic preceded by an asterisk: *RST *IDN? *SRE 8
- ◆ Subsystem commands perform specific dc source functions. They are organized into an inverted tree structure with the "root" at the top. The following figure shows a portion of a subsystem command tree, from which you access the commands located along the various paths. You can see the complete tree in Table 4-1.

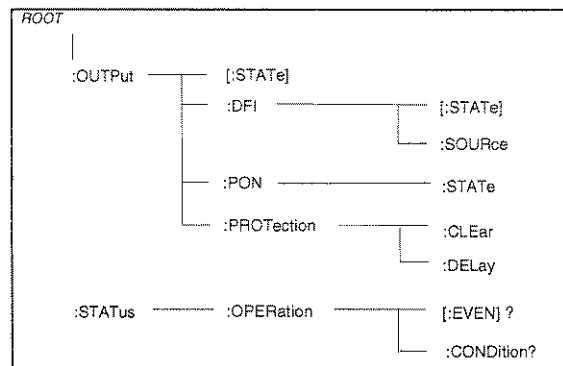

Figure 2-1. Partial Command Tree

Multiple Commands in a Message

Multiple SCPI commands can be combined and sent as a single message with one message terminator. There are two important considerations when sending several commands within a single message:

- ◆ Use a semicolon to separate commands within a message.
- ◆ There is an implied header path that affects how commands are interpreted by the dc source.

The header path can be thought of as a string that gets inserted **before** each command within a message. For the first command in a message, the header path is a null string. For each subsequent command the header path is defined as the characters that make up the headers of the previous command in the message up to and including the last colon separator. An example of a message with two commands is:

```
CURR:LEV 3;PROT:STAT OFF
```

which shows the use of the semicolon separating the two commands, and also illustrates the header path concept. Note that with the second command, the leading header "CURR" was omitted because after the "CURR:LEV 3" command, the header path was became defined as "CURR" and thus the instrument interpreted the second command as:

```
CURR:PROT:STAT OFF
```

In fact, it would have been syntactically incorrect to include the "CURR" explicitly in the second command, since the result after combining it with the header path would be:

```
CURR:CURR:PROT:STAT OFF
```

which is incorrect.

Moving Among Subsystems

In order to combine commands from different subsystems, you need to be able to reset the header path to a null string within a message. You do this by beginning the command with a colon (:), which discards any previous header path. For example, you could clear the output protection and check the status of the Operation Condition register in one message by using a root specifier as follows:

```
OUTPut:PROtEction:CLEAr;:STATus:OPERation:CONDition?
```

The following message shows how to combine commands from different subsystems as well as within the same subsystem:

```
VOLTage:LEVel 20;PROtEction 28; :CURRent:LEVel 3;PROtEction:STATe ON
```

Note the use of the optional header LEVel to maintain the correct path within the voltage and current subsystems, and the use of the root specifier to move between subsystems.

Including Common Commands

You can combine common commands with system commands in the same message. Treat the common command as a message unit by separating it with a semicolon (the message unit separator). Common commands *do not affect the header path*; you may insert them anywhere in the message.

```
VOLTage:TRIGgered 17.5;:INITialize;*TRG  
OUTPut OFF;*RCL 2;OUTPut ON
```

Using Queries

Observe the following precautions with queries:

- ◆ Set up the proper number of variables for the returned data.
- ◆ Read back all the results of a query before sending another command to the dc source. Otherwise a *Query Interrupted* error will occur and the unreturned data will be lost.

Types of SCPI Messages

There are two types of SCPI messages, program and response.

- ◆ A *program message* consists of one or more properly formatted SCPI commands sent from the controller to the dc source. The message, which may be sent at any time, requests the dc source to perform some action.
- ◆ A *response message* consists of data in a specific SCPI format sent from the dc source to the controller. The dc source sends the message only when commanded by a program message called a "query."

The following figure illustrates SCPI message structure:

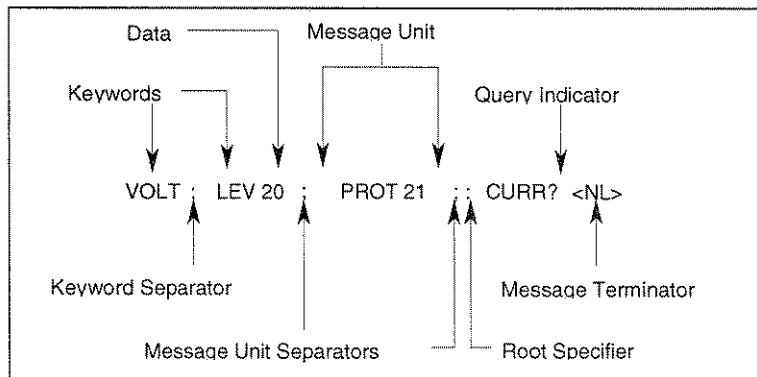

Figure 2-2. Command Message Structure

The Message Unit

The simplest SCPI command is a single message unit consisting of a command header (or keyword) followed by a message terminator. The message unit may include a parameter after the header. The parameter can be numeric or a string.

```
ABORT<NL>
VOLTage 20<NL>
```

Headers

Headers, also referred to as keywords, are instructions recognized by the dc source. Headers may be either in the long form or the short form. In the long form, the header is completely spelled out, such as VOLTAGE, STATUS, and DELAY. In the short form, the header has only the first three or four letters, such as VOLT, STAT, and DEL.

Query Indicator

Following a header with a question mark turns it into a query (VOLTage?, VOLTage:PROTection?). If a query contains a parameter, place the query indicator at the end of the last header (VOLTage:PROTection? MAX).

Message Unit Separator

When two or more message units are combined into a compound message, separate the units with a semicolon (STATus:OPERation?;QUESTionable?).

Root Specifier

When it precedes the first header of a message unit, the colon becomes the root specifier. It tells the command parser that this is the root or the top node of the command tree.

Message Terminator

A terminator informs SCPI that it has reached the end of a message. Three permitted message terminators are:

- ◆ newline (<NL>), which is ASCII decimal 10 or hex 0A.
- ◆ end or identify (<END>)
- ◆ both of the above (<NL><END>).

In the examples of this guide, there is an assumed message terminator at the end of each message.

NOTE: All RS-232 response data sent by the dc source is terminated by the ASCII character pair <carriage return><newline>. This differs from GPIB response data which is terminated by the single character <newline> with EOI asserted.

SCPI Data Formats

All data programmed to or returned from the dc source is ASCII. The data may be numerical or character string.

Numerical Data Formats

Symbol	Data Form
	<u>Talking Formats</u>
<NR1>	Digits with an implied decimal point assumed at the right of the least-significant digit. Examples: 273
<NR2>	Digits with an explicit decimal point. Example: .0273
<NR3>	Digits with an explicit decimal point and an exponent. Example: 2.73E+2
	<u>Listening Formats</u>
<Nrf>	Extended format that includes <NR1>, <NR2> and <NR3>. Examples: 273 273. 2.73E2
<Nrf+>	Expanded decimal format that includes <Nrf> and MIN MAX . Examples: 273 273. 2.73E2 MAX. MIN and MAX are the minimum and maximum limit values that are implicit in the range specification for the parameter.
<Bool>	Boolean Data. Example: 0 1 or ON OFF

Suffixes and Multipliers

Class	Suffix	Unit	Unit with Multiplier
Current	A	ampere	MA (milliampere)
Amplitude	V	volt	MV (millivolt)
Time	S	second	MS (millisecond)
Common Multipliers			
	1E3	K	kilo
	1E-3	M	milli
	1E-6	U	micro

Response Data Types

Character strings returned by query statements may take either of the the following forms, depending on the length of the returned string:

- <CRD> Character Response Data. Permits the return of character strings.
- <AARD> Arbitrary ASCII Response Data. Permits the return of undelimited 7-bit ASCII. This data type has an implied message terminator.
- <SRD> String Response Data. Returns string parameters enclosed in double quotes.

SCPI Command Completion

SCPI commands sent to the dc source are processed either sequentially or in parallel. Sequential commands finish execution before a subsequent command begins. Parallel commands allow other commands to begin executing while the parallel command is still executing. Commands that affect trigger actions are among the parallel commands.

The *WAI, *OPC, and *OPC? common commands provide different ways of indicating when all transmitted commands, including any parallel ones, have completed their operations. The syntax and parameters for these commands are described in chapter 4. Some practical considerations for using these commands are as follows:

*WAI	This prevents the dc source from processing subsequent commands until all pending operations are completed.
*OPC?	This places a 1 in the Output Queue when all pending operations have completed. Because it requires your program to read the returned value before executing the next program statement, *OPC? can be used to cause the controller to wait for commands to complete before proceeding with its program.
*OPC	This sets the OPC status bit when all pending operations have completed. Since your program can read this status bit on an interrupt basis, *OPC allows subsequent commands to be executed.

NOTE: The trigger subsystem must be in the Idle state in order for the status OPC bit to be true. Therefore, as far as triggers are concerned, OPC is false whenever the trigger subsystem is in the Initiated state.

Using Device Clear

You can send a device clear at any time about a SCPI command that may be hanging up the GPIB interface. The status registers, the error queue, and all configuration states are left unchanged when a device clear message is received. Device clear performs the following actions:

- ◆ The input and output buffers of the dc source are cleared.
- ◆ The dc source is prepared to accept a new command string.

The following statement shows how to send a device clear over the GPIB interface using *Agilent BASIC*:

```
CLEAR 705      IEEE-488 Device Clear
```

The following statement shows how to send a device clear over the GPIB interface using the GPIB command library for *C* or *QuickBASIC*:

```
IOCLEAR (705)
```

NOTE: For RS-232 operation, sending a Break will perform the same operation as the IEE-488 device clear message.

Programming the DC Source

Introduction

This chapter contains examples on how to program your dc source. Simple examples show you how to program:

- ◆ output functions such as voltage and current
- ◆ internal and external triggers
- ◆ measurement functions
- ◆ the status and protection functions

NOTE: These examples in this chapter show which commands are used to perform a particular function, but do not show the commands being used in any particular programming environment. Refer to Appendix D for some examples of SCPI commands in a specific programming environment.

Programming the Output

Power-on Initialization

When the dc source is first turned on, it wakes up with the output state set OFF. In this state the output voltage is set to 0. The following commands are given implicitly at power-on:

```
*RST
*CLS
STATus:PRESet
*SRE 0
*ESE 0
```

*RST is a convenient way to program all parameters to a known state. Refer to the *RST command in chapter 4 to see how each programmable parameter is set by *RST. Refer to the *PSC command in chapter 4 for more information on the power-on initialization of the *ESE and the *SRE registers.

Enabling the Output

To enable the output, use the command:

```
OUTPut ON
```

3 - Programming the DC Source

Output Voltage

The output voltage is controlled with the VOLTage command. For example, to set the output voltage to 25 volts, use:

```
VOLTage 25
```

The dc source can be programmed to turn off its output if the output voltage exceeds a preset peak voltage limit. This protection feature is implemented with the VOLTage:PROTection command as explained in chapter 4.

Maximum Voltage

The maximum rms output voltage that can be programmed can be queried with:

```
VOLTage? MAX
```

Output Current

All models have a programmable current function. The command to program the current is:

```
CURRent <n>
```

where <n> is the current limit in amperes.

If the load attempts to draw more current than the programmed limit, the output voltage is reduced to keep the current within the limit.

Maximum Current

The maximum output current that can be programmed can be queried with:

```
CURRent? MAX
```

Overcurrent Protection

The dc source can also be programmed to turn off its output if the current limit is reached. As explained in chapter 4, this protection feature is implemented the following command:

```
CURRent:PROTection:STATe ON | OFF
```

NOTE: Use OUTP:PROT:DEL to prevent momentary current limit conditions caused by programmed output changes from tripping the overcurrent protection.

Triggering Output Changes

The dc source has two independent trigger systems. One is used for generating output changes, and the other is used for triggering measurements. This section describes the output trigger system. The measurement trigger system is described under "Triggering Measurements".

SCPI Triggering Nomenclature

In SCPI terms, trigger systems are called sequences. When more than one trigger system exists, they are differentiated by naming them SEQUENCE1 and SEQUENCE2. SEQUENCE1 is the transient trigger system and SEQUENCE2 is the measurement trigger system. The dc source uses aliases with more descriptive names for these sequences. These aliases can be used instead of the sequence forms.

Sequence Form	Alias
SEQUENCE1	TRANSIENT
SEQUENCE2	ACQUIRE

Output Trigger System Model

Figure 3-1 is a model of the output trigger system. The rectangular boxes represent states. The arrows show the transitions between states. These are labeled with the input or event that causes the transition to occur.

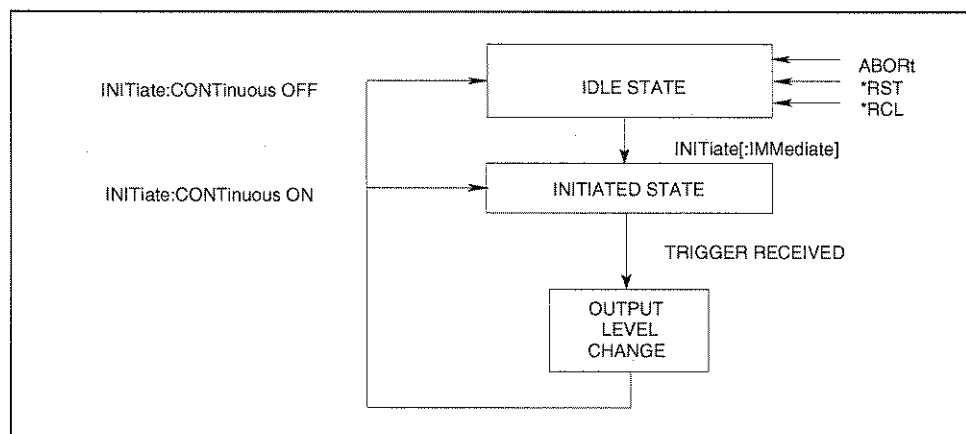

Figure 3-1. Model of Output Triggers

Setting the Voltage or Current Trigger Levels

To program output trigger levels, you must first specify a voltage or current trigger level that the output will go to once a trigger signal is received. Use the following commands to set the output trigger level:

```
VOLTage:TRIGgered <n>    or
CURRENT:TRIGgered <n>
```

NOTE: Until they are programmed, uninitialized trigger levels will assume their corresponding immediate levels. For example, if a dc source is powered up and VOLTage:LEVel is programmed to 6, then VOLTage:LEVel:TRIGger will also be 6 until you program it to another value. Once you program VOLTage:LEVel:TRIGger to a value, it will remain at that value regardless of how you subsequently reprogram VOLTage:LEVel.

Initiating the Output Trigger System

When the dc source is turned on, the trigger subsystem is in the idle state. In this state, the trigger subsystem ignores all triggers. Sending the following commands at any time returns the trigger system to the Idle state:

```
ABORt
*RST
*RCL
```

The INITiate commands move the trigger system from the Idle state to the Initiated state. This enables the dc source to receive triggers. To initiate for a single triggered action, use:

```
INITiate:SEQuence1or
INITiate:NAME TRANsient
```

After a trigger is received and the action completes, the trigger system will return to the Idle state. Thus it will be necessary to initiate the system each time a triggered action is desired.

To keep a trigger system initiated for multiple actions without having to send an initiate command for each trigger, use:

```
INITiate:CONTInuous:SEQuence1 ON or
INITiate:CONTInuous:NAME TRANsient, ON
```

Generating Triggers

You can only program output triggers over the GPIB bus. Since BUS is the only trigger source for output triggers, the following command is provided for completeness only:

```
TRIGger:SOURce BUS
```

After you have specified the appropriate trigger source, you can generate triggers as follows:

Single Triggers Send one of the following commands over the GPIB:

```
TRIGger:IMMediate
*TRG
a group execute trigger
```

Continuous Triggers Send the following command over the GPIB:

```
INITiate:CONTInuous:SEQuence1 ON
```

When the trigger system enters the Output Change state upon receipt of a trigger (see figure 3-1), the triggered functions are set to their programmed trigger levels. When the triggered actions are completed, the trigger system returns to the Idle state.

Making Measurements

The dc source has the ability to make several types of voltage or current measurements. The measurement capabilities of the Agilent 66312A and Agilent 66332A models are particularly useful for loads that draw current in pulses.

NOTE: You cannot measure output voltage and current simultaneously.

All measurements are performed by digitizing the instantaneous output voltage or current for a defined number of samples and sample interval, storing the results in a buffer, and then calculating the measured result. Many parameters of the measurement are programmable. These include the number of samples, the time interval between samples, the bandwidth, and the method of triggering. Note that there is a tradeoff between these parameters and the speed, accuracy, and stability of the measurement in the presence of noise.

There are two ways to make measurements:

- ◆ Use the MEASure commands to immediately start acquiring new voltage or current data, and return measurement calculations from this data as soon as the buffer is full. This is the easiest way to make measurements, since it requires no explicit trigger programming.
- ◆ Use an acquisition trigger to acquire the data. Then use the FETCh commands to return calculations from the data that was retrieved by the acquisition trigger. This method gives you the flexibility to synchronize the data acquisition with a transition in the output voltage or current. FETCh commands do not trigger the acquisition of new measurement data, but they can be used to return many different calculations from the data that was retrieved by the acquisition trigger. Note that if you take a voltage measurement, you can fetch only voltage data.

Making triggered measurements with the acquisition trigger system is discussed under "Triggering Measurements".

NOTE: For each MEASure form of the query, there is a corresponding query that begins with the header FETCh. FETCh queries perform the same calculation as their MEASure counterparts, but do not cause new data to be acquired. Data acquired by an explicit trigger or a previously programmed MEASure command are used.

Voltage and Current Measurements

The SCPI language provides a number of MEASure and FETCh queries which return various measurement parameters of voltage and current waveforms.

DC Measurements

To measure the dc output voltage or current, use:

```
MEASure:VOLTage? or
MEASure:CURRent?
```

Dc voltage and current is measured by acquiring a number of readings at the selected time interval, applying a Hanning window function to the readings, and averaging the readings. Windowing is a signal conditioning process that reduces the error in dc measurements made in the presence of periodic signals such as line ripple. At power-on and after a *RST command, the following parameters are set:

```
SENSE:SWEEP:TINTERval 15.6E-6
SENSE:SWEEP:POINTS 2048
```

3 - Programming the DC Source

This results in a data acquisition time of 32 milliseconds. Adding a command processing overhead of about 20 milliseconds results in a total measurement time of about 50 milliseconds per measurement sample.

Ripple rejection is a function of the number of cycles of the ripple frequency contained in the acquisition window. More cycles in the acquisition window results in better ripple rejection. If you increase the time interval for each measurement to 45 microseconds for example, this results in 5.53 cycles in the acquisition window at 60 Hz, for a ripple rejection of about 70 dB.

Note that the speed of the measurement can be increased by reducing the number of sample points. For example, the commands

```
SENSE:SWEEP:TInterval 15E-6  
SENSE:SWEEP:POINTS 1024
```

speeds up the acquisition period to 16 milliseconds; however, the tradeoff is reduced measurement accuracy.

RMS Measurements (Agilent 66312A, 66332A Only)

To read the rms content of a voltage or current waveform, use:

```
MEASURE:VOLTage:ACDC? or  
MEASURE:CURRENT:ACDC?
```

This returns the total rms measurement, including the dc portion.

Making rms measurements on ac waveforms for which a non-integral number of cycles of data has been acquired may result in measurement errors due to the last partial cycle of acquired data. The instrument reduces this error by using a Hanning window function when making the measurement.

Minimum and Maximum Measurements (Agilent 66312A, 66332A Only)

To measure the maximum or minimum voltage or current of a pulse or ac waveform, use:

```
MEASURE:VOLTage:MAXimum?  
MEASURE:VOLTage:MINimum?  
MEASURE:CURRENT:MAXimum?  
MEASURE:CURRENT:MINimum?
```

Current Ranges

The dc source has two current measurement ranges. The command that controls the ranges is:

```
SENSE:CURRENT:RANGE MIN | MAX
```

When the range is set to MIN, the maximum current that can be measured is 20 milliamperes.

Returning Measurement Data From the Data Buffer (Agilent 66312A, 66332A Only)

The MEASURE and FETCH queries can also return all data values of the instantaneous voltage or current buffer. The commands are:

```
MEASURE:ARRAY:CURRENT?  
MEASURE:ARRAY:VOLTage?
```

Internally Triggered Measurements

You can use the data acquisition trigger system to synchronize the timing of the voltage and current data acquisition with a BUS or internal trigger source. Then use the FETCh commands to return different calculations from the data acquired by the measurement trigger.

SCPI Triggering Nomenclature

As previously explained under "Triggering Output Changes", the dc source uses the following sequence name and alias for the measurement trigger system. This alias can be used instead of the sequence form.

Sequence Form	Alias
SEquence2	ACQuire

Measurement Trigger System Model

Figure 3-2 is a model of the measurement trigger system. The rectangular boxes represent states. The arrows show the transitions between states. These are labeled with the input or event that causes the transition to occur.

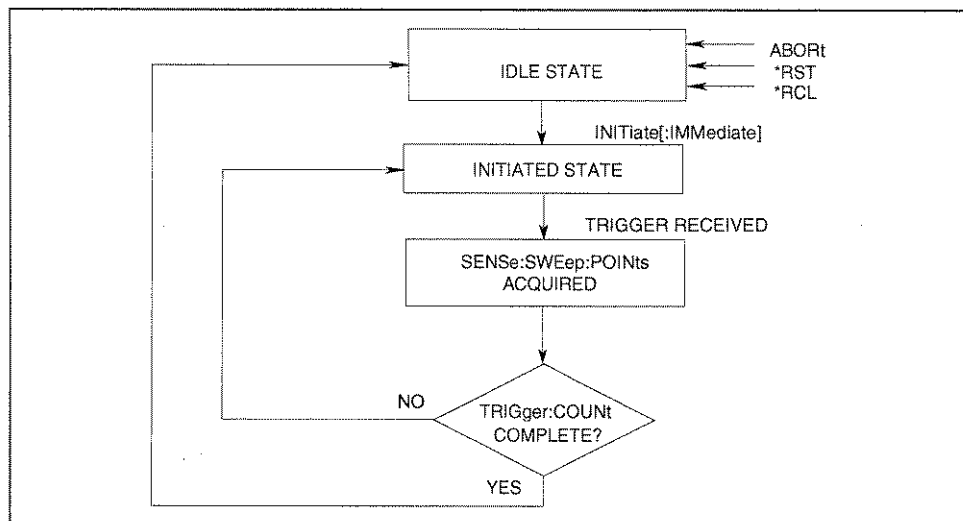

Figure 3-2. Model of Measurement Triggers

Initiating the Measurement Trigger System (Agilent 66312A, 66332A Only)

When the dc source is turned on, the trigger system is in the idle state. In this state, the trigger system ignores all triggers. Sending the following commands at any time returns the trigger system to the Idle state:

```

ABORT
*RST
*RCL
  
```

The INITiate commands move the trigger system from the Idle state to the Initiated state. This enables the dc source to receive triggers. To initiate for a measurement trigger, use:

3 - Programming the DC Source

```
INITiate:SEquence2 or  
INITiate:NAME ACQuire
```

After a trigger is received and the data acquisition completes, the trigger system will return to the Idle state (unless multiple measurements are desired). Thus it will be necessary to initiate the system each time a triggered acquisition is desired.

NOTE: You cannot initiate measurement triggers continuously. Otherwise, the measurement data in the data buffer would continuously be overwritten by each triggered measurement.

Selecting the Measurement Trigger Source (Agilent 66312A, 66332A Only)

The trigger system is waiting for a trigger signal in the Initiated state. Before you generate a trigger, you must select a trigger source. The following measurement trigger sources can be selected:

BUS - selects GPIB bus triggers.
INTernal - selects the dc source's output as the measurement trigger.

To select GPIB bus triggers (group execute trigger, device trigger, or *TRG command), use:

```
TRIGger:SEquence2:SOURce BUS or  
TRIGger:ACQuire:SOURce BUS
```

To select internal triggers (measurements triggered off the output signal) use:

```
TRIGger:SEquence2:SOURce INTernal or  
TRIGger:ACQuire:SOURce INTernal
```

Generating Measurement Triggers (Agilent 66312A, 66332A Only)

There is only one measurement converter in the dc source. Before you generate a measurement trigger, you must specify a measurement acquisition of either voltage or current. To specify a measurement acquisition use:

```
SENSe:FUNction "CURRent" or  
SENSe:FUNction "VOLTage"
```

Providing that you have specified the appropriate trigger source and a measurement acquisition, you can generate triggers as follows:

GPIB Triggers	Send one of the following commands over the GPIB: TRIGger:IMMEDIATE (not affected by the trigger source setting) *TRG a group execute trigger
Internal Triggers	To trigger off of the output signal, you must specify the output level that generates the trigger, the rising or falling edge of the slope, and a hysteresis to qualify trigger conditions. This is illustrated in figure 3-3.

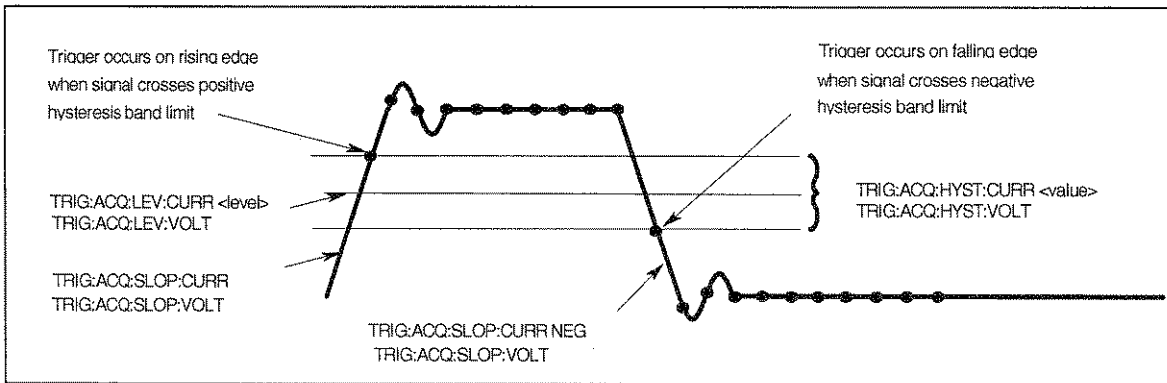

Figure 3-3. Trigger Commands Used to Measure Output Pulses

To specify the output level that will generate triggers for both positive- and negative-going signals use:

```
TRIGger:SEquence2:LEVel:CURRent <value> or
TRIGger:ACQuire:LEVel:CURRent <value>
```

To specify the slope on which triggering occurs use the following commands. You can specify a POSitive, a NEGative, or EITHER type of slope.

```
TRIGger:SEquence2:SLOPe:CURRent <slope> or
TRIGger:ACQuire:SLOPe:CURRent <slope>
```

To specify a hysteresis band to qualify the positive- or negative-going signal use:

```
TRIGger:SEquence2:HYSTeresis:CURRent <value> or
TRIGger:ACQuire:HYSTeresis:CURRent <value>
```

NOTE: When using internal triggers, do not INITiate the measurement until after you have specified the slope, level, and hysteresis.

When the acquisition finishes, any of the FETCH queries can be used to return the results. Once the measurement trigger is initiated, if a FETCH query is sent before the data acquisition is triggered or before it is finished, the response data will be delayed until the trigger occurs and the acquisition completes. This may tie up the controller if the trigger condition does not occur immediately.

One way to wait for results without tying up the controller is to use the SCPI command completion commands. For example, you can send the *OPC command after INITialize, then occasionally poll the OPC status bit in the standard event status register for status completion while doing other tasks. You can also set up an SRQ condition on the OPC status bit going true, and do other tasks until an SRQ interrupt occurs.

Measuring Output Pulses (Agilent 66312A, 66332A Only)

Current Detector

Check that the current detector is set to ACDC when measuring current pulses or other waveforms with a frequency content greater than a few kilohertz.

```
SENSE:CURRENT:DETECT ACDC
```

Only select DC as the measurement detector if you are making only DC current measurements and you require a measurement offset better than 2mA on the High current measurement range. Note that this selection gives inaccurate results on current waveforms that have ac content.

```
SENSE:CURRENT:DETECT DC
```

Pulse Measurement Queries

The dc source has several measurement queries that return key parameters of pulsed waveforms as shown in Figure 3-4.

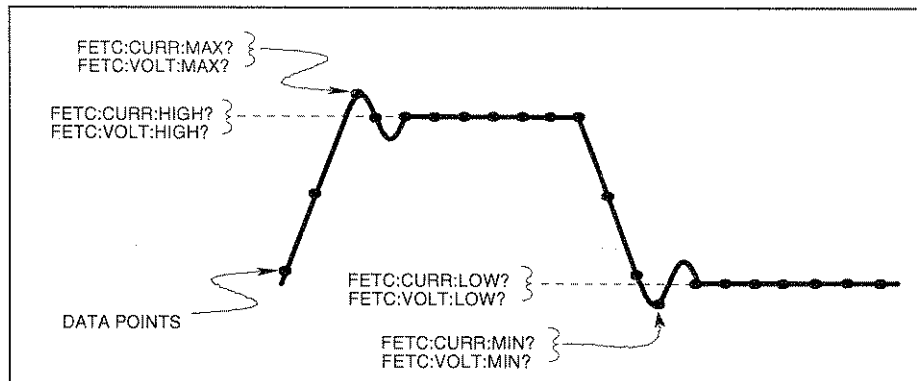

Figure 3-4. Measurement Commands Used to Return Pulse Data

To return the maximum or minimum value of a pulse waveform use the following commands. Note that the data points of the measurement sample may not coincide with the actual maximum or minimum point on the waveform.

```

FETCh:VOLTage:MAXimum? or
FETCh:VOLTage:MINimum?
FETCh:CURREnt:MAXimum? or
FETCh:CURREnt:MINimum?

```

The average value of the high level or low level of a pulse can also be measured. To return the average value of the high level, use:

```

FETCh:CURREnt:HIG? or
FETCh:VOLTage:HIG?

```

To return the average value of the low level, use:

```

FETCh:CURREnt:LOW? or
FETCh:VOLTage:LOW?

```

Controlling Measurement Samples

Varying the Voltage or Current Sampling Rate

You can vary both the number of data points in a measurement sample, as well as the time between samples. This is illustrated in Figure 3-5.

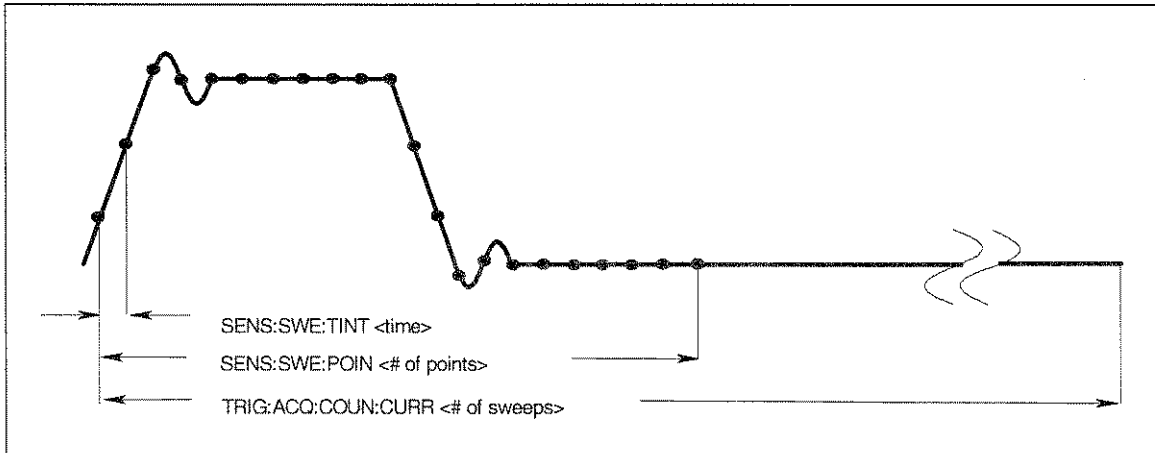

Figure 3-5. Sense Commands Used to Vary the Sampling Rate

At *RST, the output voltage or current sampling rate is 15.6 microseconds. This means that it takes about 32 milliseconds to fill up 2048 data points in the data buffer. You can vary this data sampling rate with:

```
SENSE:SWEep:TINTerval <sample_period>
SENSE:SWEep:POINTs <points>
```

For example, to set the time interval to 46.8 microseconds per sample with 1500 samples, use
`SENSE:SWEep:TINTerval 46.8E-6;POINTs 1500.`

Multiple Measurements (Agilent 66312A, 66332A Only)

The instrument also has the ability to set up several acquisition triggers in succession and average the results from each acquisition in the returned measurement. To set up the trigger system for a number of sequential acquisitions use:

```
TRIGger:ACQuire:COUNT:CURRent <number> or
TRIGger:ACQuire:COUNT:VOLTage <number>
```

With this setup, the instrument performs each acquisition sequentially, storing the digitized readings in the internal measurement buffer. It is only necessary to initialize the measurement once at the start; after each completed acquisition the instrument will wait for the next valid trigger condition to start another. The results returned by MEASure or FETCh will be the average of the total data acquired.

NOTE: The total number of data points cannot exceed 4096. This means that the product of the trigger count multiplied by the sweep points cannot exceed 4096; otherwise an error will occur.

Pre-event and Post-event Triggering (Agilent 66312A, 66332A Only)

When a measurement is initiated, the dc source continuously samples either the instantaneous output voltage or current. As shown in figure 3-6, you can move the block of data being read into the acquisition buffer with reference to the acquisition trigger. This permits pre-event or post-event data sampling.

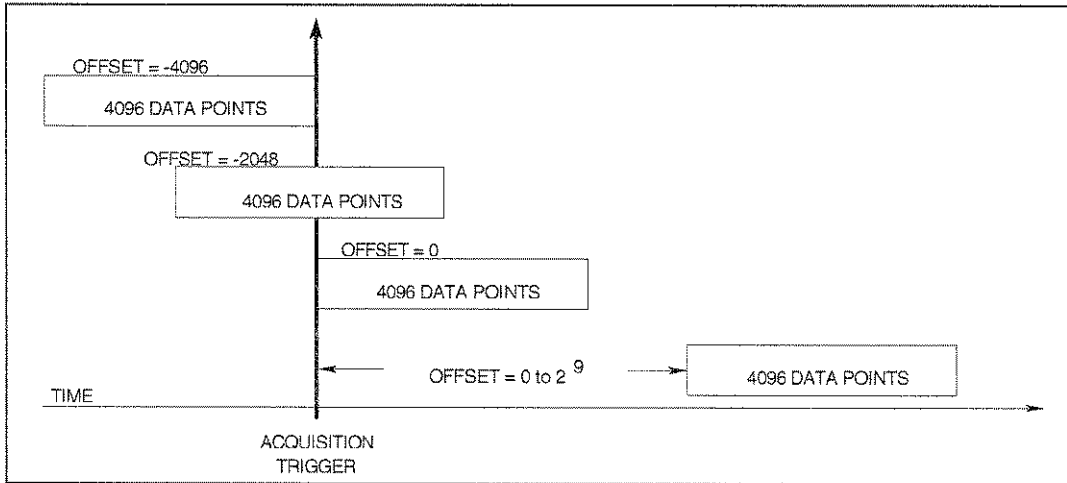

Figure 3-6. Pre-event and Post-event Triggering

To offset the beginning of the acquisition buffer relative to the acquisition trigger, use:

```
SENSE:SWEEP:OFFSET:POINTS <offset>
```

The range for the offset is -4096 to 2,000,000,000 points. As shown in the figure, when the offset is negative, the values at the beginning of the data record represent samples taken prior to the trigger. When the value is 0, all of the values are taken after the trigger. Values greater than zero can be used to program a delay time from the receipt of the trigger until the data points that are entered into the buffer are valid. (Delay time = Offset X Sample period)

Pulse Measurement Example (Agilent 66312A, 66332A only)

The following program illustrates how to make a pulse measurement over the GPIB. The measurement function is set to ACDC, which gives the best results for current waveforms that have ac content. The measurement incorporates 100 readings taken at time intervals of 20 microseconds, for a total measurement time of 2 milliseconds. The trigger point for the pulse measurement occurs at 0.1 amperes on the positive slope of the current pulse. The measurement offset is programmed so that 20 measurement points prior to the trigger are also returned as part of the measurement sample.

Because measurement triggers are initiated by the current pulse, a FETCH command is used to return the measurement data. FETCH commands are also used to return the MAXimum, MINimum, HIGH, and LOW values of the measurement.

NOTE: MEASURE commands cannot be used to return data in this example because they always acquire NEW measurement data each time they are used.

The program can be run on any controller operating under Agilent BASIC. To generate output pulses, an electronic load is programmed to generate 3-ampere pulses with a duty cycle of 100 microseconds at 1000 Hz. The power supply address is 705, and the load address is 706. If required, change these parameters in the appropriate statements.

```

10 !Rev A.00.00
20 OPTION BASE 1
30 DIM Curr_array(100)
40 !
50 ASSIGN @Ps TO 705
60 ASSIGN @Ld TO 706
80 OUTPUT @Ps;"*RST" ! Sets supply to default values
90 OUTPUT @Ps;"OUTP ON" ! Turn on power supply output
100 OUTPUT @Ps;"VOLT 5;CURR 5" ! Program power supply to 5 volts, 5 amps
110 !
120 OUTPUT @Ld;"CURR:LEVEL 0" ! Set up electronic load to produce pulses
130 OUTPUT @Ld;"CURR:TLEVEL 3"
140 !
150 OUTPUT @Ld;"TRAN:FREQ 1000"
160 OUTPUT @Ld;"TRAN:DCYCLE 10"
170 OUTPUT @Ld;"TRAN:MODE CONT"
180 OUTPUT @Ld;"TRAN:STATE ON"
190 !
200 OUTPUT @Ps;"SENS:CURR:DET ACDC" ! Set meter to ACDC
210 OUTPUT @Ps;"SENS:CURR:RANG MAX" ! High Current range
220 OUTPUT @Ps;"TRIG:ACQ:SOUR INT" ! Set to trigger on pulse
230 OUTPUT @Ps;"SENS:FUNC ""CURR"" ! Acquire current reading
240 OUTPUT @Ps;"TRIG:ACQ:LEV:CURR .1" ! Trigger at 0.1 amps
250 OUTPUT @Ps;"TRIG:ACQ:SLOPE:CURR POS" ! Trigger on positive slope
260 OUTPUT @Ps;"TRIG:ACQ:HYST:CURR .05" ! Set hysteresis of trigger
270 OUTPUT @Ps;"SENS:SWE:TINT 20E-6" ! Set sample time interval to 20us
280 OUTPUT @Ps;"SENS:SWE:POIN 100" ! Set number of measurement samples in sweep
290 OUTPUT 705;"SENS:SWE:OFFS:POIN -20" ! Number of sample points before trigger
300 OUTPUT @Ps;"INIT:NAME ACQ" ! Initiate the trigger system.
310 ! Controller now waits for trigger to occur.
320 OUTPUT @Ps;"FETCH:ARRAY:CURR?" ! Get the data after measurement completes.
330 !
340 ENTER @Ps;Curr_array(*) ! Enters all 100 data points
350 PRINT Curr_array(*) ! Print all data points
360 !
370 OUTPUT @Ps;"FETCH:CURR:MAX?" ! Get more data from previous measurement.
380 ENTER @Ps;Curr_max
390 PRINT "MAX CURRENT", Curr_max
400 !
410 OUTPUT @Ps;"FETCH:CURR:MIN?"
420 ENTER @Ps;Curr_min
430 PRINT "MIN CURRENT", Curr_min
440 !
450 OUTPUT @Ps;"FETCH:CURR:HIG?"
460 ENTER @Ps;Curr_hi
470 PRINT "HIGH CURRENT", Curr_hi
480 !
490 OUTPUT @Ps;"FETCH:CURR:LOW?"
500 ENTER @Ps;Curr_low
510 PRINT "LOW CURRENT", Curr_low
520 !
530 END

```

When this program runs, it returns 100 measurement data points as well as the MIN, MAX, HIGH, and LOW data in the following format:

```

.030585 .031869 .0344369 .031655 .0320829 .0325109 .0333669 .0340089
.0320825 .031449 .031227 .031441 .0337949 .0327249 .031869 .031655
.0327249 .031013 .0325109 .0333669 3.09751 3.1814 3.14266 3.13667
3.13817 3.13624 .977283 .0667496 .0245932 .0280171 .031013 .031655
.0331529 .0350788 .0348648 .0327249 .031227 .0327249 .031227 .030799
.031869 .0329389 .030371 .031655 .031869 .0329389 .031869 .0322869
.0320829 .0325109 .0333669 .0340089 .0348648 .0327249 .031227 .0327249
.0320829 .030371 .031449 .031227 .031441 .0337949 .031449 .0333669
.031441 .0337949 .030371 .031655 .031869 .0329389 .031869 .0293011
.031441 .0337949 .0327249 .031869 .031655 .031655 .0320829 .031227
.0322969 .031655 .0327249 .0340089 2.97661 3.18632 3.14523 3.13496
3.13453 3.13731 1.32438 .0836549 .0258772 .0284451 .0275891 .0329389
.0329389 .0333669 .0322969 .0333669
MAX CURRENT 3.18632
MIN CURRENT .0245932
HIGH CURRENT 3.1371
LOW CURRENT .0314077

```

Programming the Status Registers

You can use status register programming to determine the operating condition of the dc source at any time. For example, you may program the dc source to generate an interrupt (assert SRQ) when an event such as a current limit occurs. When the interrupt occurs, your program can then act on the event in the appropriate fashion.

Figure 3-7 shows the status register structure of the dc source. Table 3-1 defines the status bits. The Standard Event, Status Byte, and Service Request Enable registers and the Output Queue perform standard GPIB functions as defined in the *IEEE 488.2 Standard Digital Interface for Programmable Instrumentation*. The Operation Status and Questionable Status registers implement functions that are specific to the dc source.

Power-On Conditions

Refer to the *RST command description in chapter 4 for the power-on conditions of the status registers.

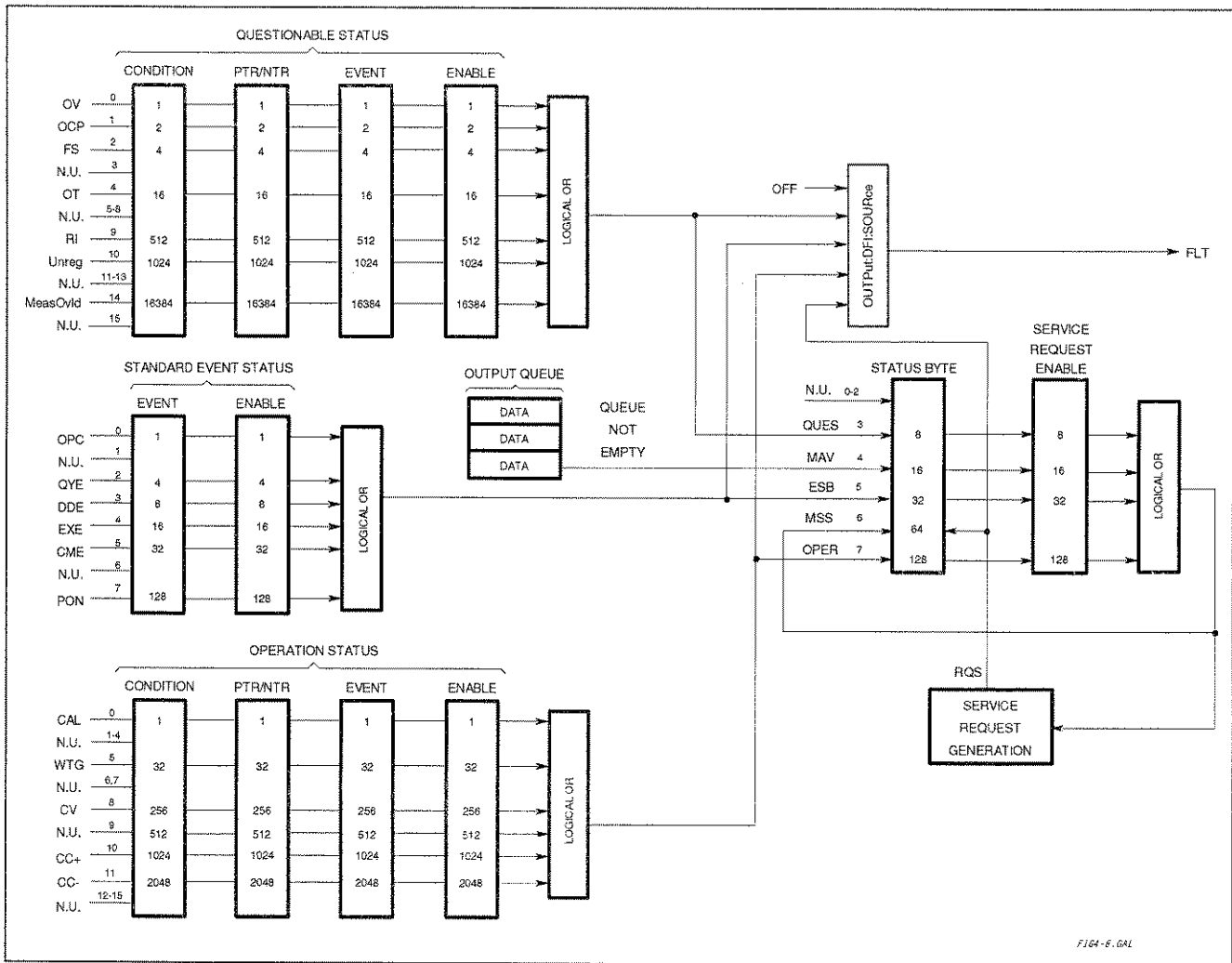

Figure 3-7. DC Source Status Model

Table 3-1. Bit Configurations of Status Registers

Bit	Signal	Meaning
0	CAL	Operation Status Group The dc source is computing new calibration constants
5	WTG	The dc source is waiting for a trigger
8	CV	The dc source is in constant voltage mode
10	CC+	The dc source is in constant current mode
11	CC-	The dc source is in negative constant current mode
0	OV	Questionable Status Group The overvoltage protection has tripped
1	OCP	The overcurrent protection has tripped
2	FS	The fuse is blown
4	OT	The overtemperature protection has tripped
9	RI	The remote inhibit state is active
10	Unreg	The output is unregulated
14	MeasOvld	Current measurement exceeded capability of low range
0	OPC	Standard Event Status Group Operation complete
2	QYE	Query error
3	DDE	Device-dependent error
4	EXE	Execution error
5	CME	Command error
7	PON	Power-on
3	QUES	Status Byte and Service Request Enable Registers Questionable status summary bit
4	MAV	Message Available summary bit
5	ESB	Event Status Summary bit
6	MSS	Master Status Summary bit
	RQS	Request Service bit
7	OPER	Operation status summary bit

Operation Status Group

The Operation Status registers record signals that occur during normal operation. As shown below, the group consists of a Condition, PTR/NTR, Event, and Enable register. The outputs of the Operation Status register group are logically-ORed into the OPER(ation) summary bit (7) of the Status Byte register.

Register	Command	Description
Condition	STAT:OPER:COND?	A register that holds real-time status of the circuits being monitored. It is a read-only register.
PTR Filter	STAT:OPER:PTR <n>	A positive transition filter that functions as described under STAT:OPER:NTR PTR commands in chapter 4. It is a read/write register.
NTR Filter	STAT:OPER:NTR <n>	A negative transition filter that functions as described under STAT:OPER:NTR PTR commands in chapter 4. It is a read/write register.
Event	STAT:OPER:EVENT?	A register that latches any condition that is passed through the PTR or NTR filters. It is a read-only register that is cleared when read.
Enable	STAT:OPER:ENAB <n>	A register that functions as a mask for enabling specific bits from the Event register. It is a read/write register.

Questionable Status Group

The Questionable Status registers record signals that indicate abnormal operation of the dc source. As shown in figure 3-7, the group consists of the same type of registers as the Status Operation group. The outputs of the Questionable Status group are logically-ORed into the QUESTIONABLE summary bit (3) of the Status Byte register.

Register	Command	Description
Condition	STAT:QUES:COND?	A register that holds real-time status of the circuits being monitored. It is a read-only register.
PTR Filter	STAT:QUES:PTR <n>	A positive transition filter that functions as described under STAT:QUES:NTR PTR commands in chapter 4. It is a read/write register.
NTR Filter	STAT:QUES:NTR <n>	A negative transition filter that functions as described under STAT:QUES:NTR PTR commands in chapter 4. It is a read/write register.
Event	STAT:QUES:EVEN?	A register that latches any condition that is passed through the PTR or NTR filters. It is a read-only register that is cleared when read.
Enable	STAT:QUES:ENAB <n>	A register that functions as a mask for enabling specific bits from the Event register. It is a read/write register..

Standard Event Status Group

This group consists of an Event register and an Enable register that are programmed by Common commands. The Standard Event event register latches events relating to instrument communication status (see figure 3-7). It is a read-only register that is cleared when read. The Standard Event enable register functions similarly to the enable registers of the Operation and Questionable status groups.

Command	Action
*ESE	programs specific bits in the Standard Event enable register.
*PSC ON	clears the Standard Event enable register at power-on.
*ESR?	reads and clears the Standard Event event register.

The PON (Power On) Bit

The PON bit in the Standard Event event register is set whenever the dc source is turned on. The most common use for PON is to generate an SRQ at power-on following an unexpected loss of power. To do this, bit 7 of the Standard Event enable register must be set so that a power-on event registers in the ESB (Standard Event Summary Bit), bit 5 of the Service Request Enable register must be set to permit an SRQ to be generated, and *PSC OFF must be sent. The commands to accomplish these conditions are:

```
*PSC OFF *ESE 128 *SRE 32
```

Status Byte Register

This register summarizes the information from all other status groups as defined in the *IEEE 488.2 Standard Digital Interface for Programmable Instrumentation*. The bit configuration is shown in Table 3-1.

Command	Action
*STB?	reads the data in the register but does not clear it (returns MSS in bit 6)
serial poll	clears RQS inside the register and returns it in bit position 6 of the response.

The MSS Bit

This is a real-time (unlatched) summary of all Status Byte register bits that are enabled by the Service Request Enable register. MSS is set whenever the dc source has one or more reasons for requesting service. *STB? reads the MSS in bit position 6 of the response but does not clear any of the bits in the Status Byte register.

The RQS Bit

The RQS bit is a latched version of the MSS bit. Whenever the dc source requests service, it sets the SRQ interrupt line true and latches RQS into bit 6 of the Status Byte register. When the controller does a serial poll, RQS is cleared inside the register and returned in bit position 6 of the response. The remaining bits of the Status Byte register are not disturbed.

The MAV Bit and Output Queue

The Output Queue is a first-in, first-out (FIFO) data register that stores dc source-to-controller messages until the controller reads them. Whenever the queue holds one or more bytes, it sets the MAV bit (4) of the Status Byte register.

Determining the Cause of a Service Interrupt

You can determine the reason for an SRQ by the following actions:

- Step 1 Determine which summary bits are active. Use:
*STB? or serial poll
- Step 2 Read the corresponding Event register for each summary bit to determine which events caused the summary bit to be set. Use:
STATUS:QUESTIONABLE:EVENT?
STATUS:OPERATION:EVENT?
ESR?
When an Event register is read, it is cleared. This also clears the corresponding summary bit.
- Step 3 Remove the specific condition that caused the event. If this is not possible, the event may be disabled by programming the corresponding bit of the status group Enable register or NTR|PTR filter. A faster way to prevent the interrupt is to disable the service request by programming the appropriate bit of the Service Request Enable register

Servicing Operation Status and Questionable Status Events

This example assumes you want a service request generated whenever the dc source switches to the CC (constant current) operating mode, or whenever the dc source's overvoltage, overcurrent, or overtemperature circuits have tripped. From figure 3-7, note the required path for a condition at bit 10 (CC) of the Operation Status register to set bit 6 (RQS) of the Status Byte register. Also note the required path for Questionable Status conditions at bits 0, 1, and 4 to generate a service request (RQS) at the Status Byte register. The required register programming is as follows:

- Step 1 Program the Operation Status PTR register to allow a positive transition at bit 10 to be latched into the Operation Status Event register, and allow the latched event to be summed into the Operation summary bit. Use:
STATUS:OPERATION:PTR 1024;ENABLE 1024
- Step 2 Program the Questionable Status PTR register to allow a positive transition at bits 0, 1, or 4 to be latched into the Questionable Status Event register, and allow the latched

3 - Programming the DC Source

event to be summed into the Questionable summary bit. Use:
STATus:QUESTionable:PTR 19;ENABLe 19 (1 + 2 + 16 = 19)

Step 3 Program the Service Request Enable register to allow both the Operation and the Questionable summary bits from the Status Byte register to generate RQS. Use:
*SRE 136 (8 + 128 = 136)

Step 4 When you service the request, read the event registers to determine which Operation Status and Questionable Status Event register bits are set, and clear the registers for the next event. Use:
STATus:OPERation:EVENT;QUESTionable:EVENT?

Monitoring Both Phases of a Status Transition

You can monitor a status signal for both its positive and negative transitions. For example, to generate RQS when the dc source either enters the CC+ (constant current) condition or leaves that condition, program the Operational Status PTR/NTR filter as follows:

```
STATus:OPERational:PTR 1024;NTR 1024  
STATus:OPERational:ENABLe 1024;*SRE 128
```

The PTR filter will cause the OPERational summary bit to set RQS when CC+ occurs. When the controller subsequently reads the event register with STATus:OPERational:EVENT?, the register is cleared. When CC+ subsequently goes false, the NTR filter causes the OPERational summary bit to again set RQS.

Inhibit/Fault Indicator

The remote inhibit(INH) and discrete fault(FLT) indicators are implemented through the respective **INH** and **FLT** connections on the rear panel. Refer to Table 1-2 for the electrical parameters.

Remote Inhibit (RI)

Remote inhibit is an external, chassis-referenced logic signal routed through the rear panel INH connection, which allows an external device to signal a fault. To select an operating modes for the remote inhibit signal, use:

```
OUTPut:RI:MODE LATCHing | LIVE | OFF
```

Discrete Fault Indicator (DFI)

The discrete fault indicator is an open-collector logic signal connected to the rear panel FLT connection, that can be used to signal external devices when a fault condition is detected. To select the internal fault source that drives this signal, use:

```
OUTPut:DFI:SOURce QUESTionable | OPERATION | ESB | RQS | OFF
```

To enable or disable the DFI output, use:

```
OUTPut:DFI:STATE ON | OFF
```

Using the Inhibit/Fault Port as a Digital I/O

You can configure the inhibit/fault port to provide a digital input/output to be used with custom digital interface circuits or relay circuits. As shipped from the factory, the port is shipped for inhibit/fault operation. You can change the configuration of the port to operate as a general purpose digital input output port with the following command:

```
[SOURCE:]DIGital:FUNCTION RIDFi | DIGio
```

The following table shows the bin assignments of the mating plug when used in RI/DFI mode as well as Digital I/O mode. Refer to Table 1-2 for the electrical characteristics of the port.

Pin	FAULT/INHIBIT	DIGITAL I/O	Bit Weight
1	FLT Output	OUT 0	0
2	FLT Output	OUT 1	1
3	INH Input	IN/OUT 2	2
4	INH Common	Common	not programmable

To program the digital I/O port use:

```
[SOURCE:]DIGital:DATA <data>
```

where the data is an integer from 0 to 7 that sets pins 1 to 3 according to their binary weight. Refer to the DIGital:DATA command for more information.

DFI Programming Example

The following program illustrates how to program the DFI port so that it goes low when an OCP condition turns off the output of the unit. To clear an overcurrent condition, the cause of the condition must first be removed and then an OUTPUT:PROTECTION:CLEAR command must be sent. Note that the status event register will not clear the DFI port until the register is read.

```
10 !Rev A.00.00
20 ASSIGN @Ps TO 705
30 OUTPUT @Ps;"*RST" ! Sets supply to default values
40 OUTPUT @Ps;"OUTP ON" ! Turn on power supply output
50 OUTPUT @Ps;"VOLT 10;CURR .1" ! Program power supply voltage and current
60 !
70 OUTPUT @Ld;"CURR:PROT:STAT ON" ! Turn on overcurrent protection
80 OUTPUT @Ld;"OUTP:DFI:STAT ON" ! Turn on DFI port
90 OUTPUT @Ld;"OUTP:DFI:SOUR QUES" ! Select DFI bit from Questionable status register
100 OUTPUT @Ld;"STAT:QUES:ENAB 2;PTR 2" ! Unmask bit 2 (OCP) on positive transition
110 !
120 OUTPUT @Ld;"OUTP:PROT:CLE" ! Clears the protection circuit
130 OUTPUT @Ld;"STAT:QUES:EVENT?" ! Clears the Event register and DFI
140 ENTER @Ld;EVENT ! Reads the event and clears the buffer
190 !
```

Language Dictionary

Introduction

This section gives the syntax and parameters for all the IEEE 488.2 SCPI commands and the Common commands used by the dc source. It is assumed that you are familiar with the material in "Chapter 2 - Remote Programming". That chapter explains the terms, symbols, and syntactical structures used here and gives an introduction to programming. You should also be familiar with "Chapter 4 - Front Panel Operation" (in the Operating Guide) in order to understand how the dc source functions.

The programming examples are simple applications of SCPI commands. Because the SCPI syntax remains the same for all programming languages, the examples given for each command are generic.

Syntax Forms	Syntax definitions use the long form, but only short form headers (or "keywords") appear in the examples. Use the long form to help make your program self-documenting.
Parameters	Most commands require a parameter and all queries will return a parameter. The range for a parameter may vary according to the model of dc source. When this is the case, refer to the Specifications table in the Operating Guide.
Models	If a command only applies to specific models, those models are listed in the <Model> Only entry. If there is no <Model> Only entry, the command applies to all models.
Related Commands	Where appropriate, related commands or queries are included. These are listed because they are either directly related by function, or because reading about them will clarify or enhance your understanding of the original command or query.
Order of Presentation	The dictionary is organized according to the following functions: calibration, measurement, output, status, system, and trigger. Both the subsystem commands and the common commands that follow are arranged in alphabetical order under each function.

Subsystem Commands

Subsystem commands are specific to functions. They can be a single command or a group of commands. The groups are comprised of commands that extend one or more levels below the root.

The subsystem command groups are grouped according to function: Calibration, Measurement, Output, Status, System, and Trigger. Commands under each function are grouped alphabetically. Commands followed by a question mark (?) take only the query form. When commands take both the command and query form, this is noted in the syntax descriptions. Table 4-1 lists all of the subsystem commands in alphabetical order.

Table 4-1. Subsystem Commands Syntax

ABORt	Resets the trigger system to the Idle state
CALibrate	:
:CURRent	
[:SOURce]	
[:DC] [:POSitive]	Calibrate positive output current and high current measurement range
:NEGative	Calibrate negative output current
:MEASure	
[:DC] :LOWRange	Calibrate low current measurement range
:AC	Calibrate ac current measurement circuits
:DATA <n>	Input a calibration measurement
:LEVel <level>	Advance to next calibration step (P1 P2)
:PASSword <n>	Set calibration password
:SAVE	Save new cal constants in non-volatile memory
:STATE <bool> [, <n>]	Enable or disable calibration mode
:VOLTage	
[:DC]	Calibrate output voltage and voltage readback
:PROTection	Begin voltage protection calibration sequence
DISPlay	
[:WINDow]	
[:STATe] <bool>	Enable/disable front panel display
:MODE <mode>	Set display mode (NORM TEXT)
:TEXT [:DATA] <string>	Sets the text that is displayed
INITiate	
[:IMMediate]	
:SEquence[<n>]	Initiate a specific numbered sequence (1 2)
:NAME <name>	Initiate a specific named sequence (TRAN ACQ)
CONTInuous	
:SEquence1, <bool>	Set continuous initialization
:NAME TRANSient, <bool>	Set continuous initialization
MEASure FETCh	
:ARRay	
:CURRent [:DC]?	Returns the digitized instantaneous current
:VOLTage [:DC]?	Returns the digitized instantaneous voltage
[:SCALar]	
:CURRent [:DC]?	Returns dc current
:ACDC?	Returns the total rms current (ac+dc)
:HIGH?	Returns the HIGH level of a current pulse
:LOW?	Returns the LOW level of a current pulse
:MAX?	Returns maximum current
:MIN?	Returns minimum current
:VOLTage [:DC]?	Returns dc voltage
:ACDC?	Returns the total rms voltage (ac+dc)
:HIGH?	Returns the HIGH level of a voltage pulse
:LOW?	Returns the LOW level of a voltage pulse
:MAX?	Returns maximum voltage
:MIN?	Returns minimum voltage

Table 4-1. Subsystem Commands Syntax (continued)

OUTPut		
[:STATe] <bool> [,NORelay]		Enables/disables the dc source output
:DFI		
[:STATe] <bool>		Enable/disable DFI output
:SOURce <source>		Selects event source (QUES OPER ESB RQS OFF)
:PON		
:STATe <state>		Set power-on state (*RST RCL0)
:PROTection		
:CLEar		Reset latched protection
:DELay <n>		Delay after programming/before protection
:RELy		
[:STATe] <bool>		Opens/closes the external relay contacts
:POLarity <polarity>		Sets the external relay polarity (NORM REV)
:RI		
:MODE <mode>		Sets remote inhibit input (LATC LIVE OFF)
SENSe		
:CURRent		
[:DC]		
RANGe [:UPPer] <n>		Selects the high current measurement range
:DETeCTOR <detector>		Selects the current measurement detector (ACDC DC)
:FUNctIon <function>		Configures the measurement sensor ("VOLT" "CURR")
:SWEep		
:OFFSet		
:POINts <n>		Defines the offset in the data sweep
:POINts <n>		Define the number of data points in a sweep
:TINterval <n>		Sets the digitizer sample spacing
:WINDow [:TYPE] <type>		Sets the measurement window function (HANN RECT)
[SOURce:]		
CURRent		
[:LEVel]		
[:IMMediate][:AMPLitude] <n>		Sets the output current level
:TRIGgered [:AMPLitude] <n>		Sets the triggered output current level
:PROTection		
:STATe <bool>		Enable/Disable current limit protection
DIGital		
:DATA [:VALue] <n>		Sets and reads the digital control port
:FUNctIon <function>		Configures digital control port (RIDF DIG)
VOLTage		
[:LEVel]		
[:IMMediate][:AMPLitude] <n>		Sets the dc voltage level
:TRIGgered [:AMPLitude] <n>		Sets the transient voltage level
:ALC		
:BANDwidth? :BWIDth?		Returns setting of output mode switch
:PROTection [:LEVel] <n>		Sets the overvoltage protection threshold

Table 4-1. Subsystem Commands Syntax (continued)

STATus	
:PRESet	Presets all enable and transition registers to power-on
:OPERation	
[:EVENT]?	Returns the value of the event register
:CONDition?	Returns the value of the condition register
:ENABle <n>	Enables specific bits in the Event register
:NTRansition<n>	Sets the Negative transition filter
:PTRansition<n>	Sets the Positive transition filter
:QUESTionable	
[:EVENT]?	Returns the value of the event register
:CONDition?	Returns the value of the condition register
:ENABle <n>	Enables specific bits in the Event register
:NTRansition<n>	Sets the Negative transition filter
:PTRansition<n>	Sets the Positive transition filter
SYSTem	
:ERRor?	Returns the error number and error string
:LANGUage <language>	Sets the programming language (SCPI COMP)
:VERSion?	Returns the SCPI version number
:LOCal	Go to local mode (for RS-232 operation)
:REMote	Go to remote mode (for RS-232 operation)
:RWLock	Go to remote with local lockout (for RS-232 operation)
TRIGger	
:SEQuence2 :ACQuire	
[:IMMEDIATE]	Triggers the measurement immediately
:COUNT	
:CURRent <n>	Sets the number of sweeps per current measurement
:VOLTage <n>	Sets the number of sweeps per voltage measurement
:HYSteresis	
:CURRent <n>	Qualifies the trigger when measuring current
:VOLTage <n>	Qualifies the trigger when measuring voltage
:LEVel	
:CURRent <n>	Sets the trigger level for measuring current
:VOLTage <n>	Sets the trigger level for measuring voltage
:SLOPe	
:CURRent <slope>	Sets the triggered current slope (POS NEG EITH)
:VOLTage <slope>	Sets the triggered voltage slope (POS NEG EITH)
:SOURce <source>	Sets the trigger source (BUS INT)
[:SEQuence1 :TRANsient]	
[:IMMEDIATE]	Triggers the output immediately
:SOURce <source>	Sets the trigger source (BUS)
:SEQuence1	
:DEFine TRANsient	Sets or queries the SEQ1 name
:SEQuence2	
:DEFine ACQuire	Sets or queries the SEQ2 name

Common Commands

Common commands begin with an * and consist of three letters (command) or three letters and a ? (query). They are defined by the IEEE 488.2 standard to perform common interface functions. Common commands and queries are categorized under System, Status, or Trigger functions and are listed at the end of each group. The dc source responds to the following commands:

Table 4-2. Common Commands Syntax

*CLS	Clear status
*ESE <n>	Standard event status enable
*ESE?	Return standard event status enable
*ESR?	Return event status register
*IDN?	Return instrument identification
*OPC	Enable "operation complete" bit in ESR
*OPC?	Return a "1" when operation complete
*OPT?	Return option number
*PSC <bool>	Power-on status clear state set/reset
*PSC?	Return power-on status clear state
*RCL <n>	Recall instrument state
*RST	Reset
*SAV <n>	Save instrument state
*SRE <n>	Set service request enable register
*SRE?	Return service request enable register
*STB?	Return status byte
*TRG	Trigger
*TST?	Perform selftest, then return result
*WAI	Hold off bus until all device commands done

Programming Parameters

The following table lists the output programming parameters for each model.

Table 4-3. Output Programming Parameters

Parameter	Value					
	66312A	66332A	6631B 6611C	6632B 6612C	6633B 6613C	6634B 6614C
[SOUR:]CURR[:LEV][:IMM] MAX and [SOUR:]CURR[:LEV]:TRIG MAX *RST Current Value	2.0475	5.1188	10.237 5.1188	5.1188 2.0475	2.0475 1.0238	1.0238 0.5118
	10% of MAX value for all models					
[SOUR:]VOLT[:LEV][:IMM]MAX and [SOUR:]VOLT[:LEV]:TRIG MAX *RST Voltage Value	20.475	20.475	8.190	20.475	51.188	102.38
	0 V for all models					
[SOUR:]VOLT:PROT[:LEV] MAX *RST OVP Value	22	22	12	22	55	110
	MAX for all models					
OUTP:PROT:DEL MAX *RST Protection Delay Value	2,147,483.647 seconds for all models 0.08 seconds					
SENS:CURR:RANG *RST Current Range	Low range = 0 – 20 mA for all models High Range = 20 mA – MAX for all models Value MAX for all models					

Calibration Commands

Calibration commands let you:

- ◆ Enable and disable the calibration mode
- ◆ Change the calibration password
- ◆ Calibrate the current and voltage programming and measurement, and store new calibration constants in nonvolatile memory.

NOTE: If calibration mode has not been enabled with CALibrate:STATE, programming the calibration commands will generate an error.

CALibrate:CURRENT

This command initiates the calibration of the positive dc output current as well as the high-range current measurement circuit.

Command Syntax CALibrate:CURRENT[:SOURCE][:DC][:POSitive]
Parameters None
Examples CAL:CURRCAL:CURR:SOUR:DC:POS
Related Commands CAL:CURR:NEG

CALibrate:CURRENT:NEGative

This command initiates the calibration of the negative dc output current.

Command Syntax CALibrate:CURRENT[:SOURCE][:DC]:NEGative
Parameters None
Examples CAL:CURR:NEGCAL:CURR:SOUR:DC:NEG
Related Commands CAL:CURR

CALibrate:CURRENT:MEASure:LOWRange

This command initiates the calibration of the low-range current measurement circuit.

Command Syntax CALibrate:CURRENT:MEASure[:DC]:LOWRange
Parameters None
Examples CAL:CURR:MEAS
Related Commands CAL:CURR

CALibrate:CURRENT:MEASure:AC

Agilent 66312A, 66332A Only

This command initiates the calibration of the high bandwidth (ac) measurement circuit.

Command Syntax CALibrate:CURRENT:MEASure:AC
Parameters None
Examples CAL:CURR:MEAS:AC

CALibrate:DATA

This command enters a calibration value that you obtain by reading an external meter. You must first select a calibration level (with CALibrate:LEVel) for the value being entered.

Command Syntax	CALibrate:DATA<NRf>	
Parameters	<external reading>	
Unit	A (amperes)	
Examples	CAL:DATA 3222.3 MA	CAL:DATA 5.000
Related Commands	CAL:STAT CAL:LEV	

CALibrate:LEVel

This command selects the next point in the calibration sequence.

P1: the first calibration point

P2: the second calibration point

Command Syntax	CALibrate:LEVel <point>
Parameters	P1 P2
Examples	CAL:LEV P2

CALibrate:PASSword

This command lets you change the calibration password. A new password is automatically stored in nonvolatile memory and does not have to be stored with CALibrate:SAVE.

If the password is set to 0, password protection is removed and the ability to enter the calibration mode is unrestricted.

Command Syntax	CALibrate:PASScode<NRf>	
Parameters	<model number> (default)	
Examples	CAL:PASS 6812	CAL:PASS 6.1994
Related Commands	CAL:SAV	

CALibrate:SAVE

This command saves any new calibration constants after a calibration procedure has been completed in nonvolatile memory. If CALibrate:STATe OFF is programmed without a CALibrate:SAVE, the previous calibration constants are restored..

Command Syntax	CALibrate:SAVE	
Parameters	None	
Examples	CAL:SAVE	
Related Commands	CAL:PASS	CAL:STAT

CALibrate:STATe

This command enables and disables calibration mode. The calibration mode must be enabled before the will accept any other calibration commands.

The first parameter specifies the enabled or disabled state. The second parameter is the password. It is required if the calibration mode is being enabled and the existing password is not 0. If the password is not entered or is incorrect, an error is generated and the calibration mode remains disabled. The query statement returns only the state, not the password.

NOTE: Whenever the calibration state is changed from enabled to disabled, any new calibration constants are lost unless they have been stored with CALibrate:SAVE.

Command Syntax	CALibrate:STATe<bool>[,<NRf>]
Parameters	0 1 OFF ON [,<password>]
*RST Value	OFF
Examples	CAL:STAT 1,6812 CAL:STAT OFF
Query Syntax	CALibrate:STATe?
Returned Parameters	<NR1>
Related Commands	CAL:PASS CAL:SAVE *RST

CALibrate:VOLTage

This command initiates the calibration of the output voltage and the voltage readback circuit.

Command Syntax	CALibrate:VOLTage[:DC]
Parameters	None
Examples	CAL:VOLT CAL:VOLT:DC

CALibrate:VOLTage:PROTection

This command can calibrates the overvoltage protection (OV) circuit. The dc source automatically performs the calibration. CALibrate:VOLTage:PROTection is a sequential command that takes several seconds to complete.

Command Syntax	CALibrate:VOLTage:PROTection
Parameters	None
Examples	CAL:VOLT:PROT

Measurement Commands

Measurement commands consist of measure and sense commands.

Measure commands measure the output voltage or current. Measurements are performed by digitizing the instantaneous output voltage or current for a defined number of samples and sample interval, storing the results in a buffer, and calculating the measured result. Two types of measurement commands are available: MEASure and FETCh. MEASure triggers the acquisition of new data before returning the reading; FETCh returns a reading computed from previously acquired data. If you take a voltage measurement, you can fetch only voltage data.

- ◆ Use MEASure when the measurement does not need to be synchronized with any other event.
- ◆ Use FETCh when it is important that the measurement be synchronized with either a trigger or with a particular part of the output waveform.

Sense commands control the current measurement range, the bandwidth detector of the , and the data acquisition sequence.

MEASure:ARRay:CURRent?

FETCh:ARRay:CURRent?

Agilent 66312A, 66332A Only

These queries return an array containing the instantaneous output current in amperes. The output voltage or output current are digitized whenever a measure command is given or whenever an acquire trigger occurs. The time interval is set by SENSE:SWEep:TINTerval. The position of the trigger relative to the beginning of the data buffer is determined by SENSE:SWEep:OFFSet. The number of points returned is set by SENSE:SWEep:POINts.

Query Syntax	MEASure:ARRay:CURRent[:DC]? FETCh:ARRay:CURRent[:DC]?
Parameters	None
Examples	MEAS:ARR:CURR? FETC:ARR:CURR?
Returned Parameters	<NR3>
Related Commands	SENS:SWE:TINT SENS:SWE:OFFS SENS:SWE:POIN

MEASure:ARRay:VOLTage?

FETCh:ARRay:VOLTage?

Agilent 66312A, 66332A Only

These queries return an array containing the instantaneous output voltage in volts. The output voltage or output current are digitized whenever a measure command is given or whenever an acquire trigger occurs. The time interval is set by SENSE:SWEep:TINTerval. The position of the trigger relative to the beginning of the data buffer is determined by SENSE:SWEep:OFFSet. The number of points returned is set by SENSE:SWEep:POINts.

Query Syntax	MEASure:ARRay:VOLTage[:DC]? FETCh:ARRay:VOLTage[:DC]?
Parameters	None
Examples	MEAS:ARR:VOLT? FETC:ARR:VOLT?
Returned Parameters	<NR3>
Related Commands	SENS:SWE:TINT SENS:SWE:OFFS SENS:SWE:POIN

MEASure:CURRent?
FETCh:CURRent?

FETCh:CURRent? applies to Agilent 66312A, 66332A Only

These queries return the dc output current.

Query Syntax	MEASure:[SCALar]:CURRent[:DC]?
	FETCh:[SCALar]:CURRent[:DC]?
Parameters	None
Examples	MEAS : CURR? MEAS : CURR : DC?
Returned Parameters	<NR3>
Related Commands	MEAS:VOLT?

MEASure:CURRent:ACDC?
FETCh:CURRent:ACDC?

Agilent 66312A, 66332A Only

These queries return the ac+dc rms output current.

Query Syntax	MEASure:[SCALar]:CURRent:ACDC?
	FETCh:[SCALar]:CURRent:ACDC?
Parameters	None
Examples	MEAS : CURR : ACDC? FETC : CURR : ACDC?
Returned Parameters	<NR3>
Related Commands	MEAS:VOLT:ACDC?

MEASure:CURRent:HIGh?
FETCh:CURRent:HIGh?

Agilent 66312A, 66332A Only

These queries return the High level current of a current pulse waveform. The instrument first measures the minimum and maximum data points of the pulse waveform. It then generates a histogram of the pulse waveform using 1024 bins between the maximum and minimum data points. The bin containing the most data points above the 50% point is the high bin. The average of all the data points in the high bin is returned as the High level. If no high bin contains more than 1.25% of the total number of acquired points, then the maximum value is returned by these queries.

Query Syntax	MEASure[SCALar]:CURRent:HIGh?
	FETCh[:SCALar]:CURRent:HIGh?
Parameters	None
Examples	MEAS : CURR : HIGh? FETC : CURR : HIGh?
Returned Parameters	<NR3>
Related Commands	MEAS:CURR:LOW? CALC:REF:HIGh

MEASure:CURRent:LOW? FETCh:CURRent:LOW?

Agilent 66312A, 66332A Only

These queries return the Low level current of a current pulse waveform. The instrument first measures the minimum and maximum data points of the pulse waveform. It then generates a histogram of the pulse waveform using 1024 bins between the maximum and minimum data points. The bin containing the most data points below the 50% point is the low bin. The average of all the data points in the low bin is returned as the Low level. If no low bin contains more than 1.25% of the total number of acquired points, then the minimum value is returned by these queries.

Query Syntax	MEASure[SCALar]:CURRent:LOW? FETCh[:SCALar]:CURRent:LOW?
Parameters	None
Examples	MEAS : CURR : LOW? FETC : CURR : LOW?
Returned Parameters	<NR3>
Related Commands	MEAS:CURR:HIGH? CALC:REF:LOW

MEASure:CURRent:MAXimum? FETCh:CURRent: MAXimum?

Agilent 66312A, 66332A Only

These queries return the maximum output current reading from the measurement sample.

Query Syntax	MEASure[:SCALar]:CURRent:MAXimum? FETCh[:SCALar]:CURRent:MAXimum?
Parameters	None
Examples	MEAS : CURR : MAX? FETC : CURR : MAX?
Returned Parameters	<NR3>
Related Commands	MEAS:CURR:MIN?

MEASure:CURRent:MINimum? FETCh:CURRent:MINimum?

Agilent 66312A, 66332A Only

These queries return the minimum output current reading from the measurement sample.

Query Syntax	MEASure[:SCALar]:CURRent:MINimum? FETCh[:SCALar]:CURRent:MINimum?
Parameters	None
Examples	MEAS : CURR : MIN? FETC : CURR : MIN?
Returned Parameters	<NR3>
Related Commands	MEAS:CURR:MAX?

**MEASure:VOLTage?
FETCh:VOLTage?**

FETCh:VOLTage? applies to Agilent 66312A, 66332A Only

These queries return the dc output voltage.

Query Syntax	MEASure[:SCALar]:VOLTage[:DC]? MEASure[:SCALar]:VOLTage[:DC]?
Parameters	None
Examples	MEAS:VOLT? FETC:VOLT:DC?
Returned Parameters	<NR3>
Related Commands	MEAS:CURR?

**MEASure:VOLTage:ACDC?
FETCh:VOLTage:ACDC?**

Agilent 66312A, 66332A Only

These queries return the ac+dc rms output voltage.

Query Syntax	MEASure[:SCALar]:VOLTage:ACDC? FETCh[:SCALar]:VOLTage:ACDC?
Parameters	None
Examples	MEAS:VOLT:ACDC? FETC:VOLT:ACDC?
Returned Parameters	<NR3>
Related Commands	MEAS:CURR:ACDC?

**MEASure:VOLTage:HIGh?
FETCh:VOLTage:HIGh?**

Agilent 66312A, 66332A Only

These queries return the High level voltage of a voltage pulse waveform. The instrument first measures the minimum and maximum data points of the pulse waveform. It then generates a histogram of the pulse waveform using 1024 bins between the maximum and minimum data points. The bin containing the most data points above the 50% point is the high bin. The average of all the data points in the high bin is returned as the High level. If no high bin contains more than 1.25% of the total number of acquired points, then the maximum value is returned by these queries.

Query Syntax	MEASure[SCALar]:VOLTage:HIGh? FETCh[:SCALar]:VOLTage:HIGh?
Parameters	None
Examples	MEAS:VOLT:HIGh? FETC:VOLT:HIGh?
Returned Parameters	<NR3>
Related Commands	MEAS:VOLT:LOW? CALC:REF:HIGh

MEASure:VOLTage:LOW? FETCh:VOLTage:LOW?

Agilent 66312A, 66332A Only

These queries return the Low level voltage of a voltage pulse waveform. The instrument first measures the minimum and maximum data points of the pulse waveform. It then generates a histogram of the pulse waveform using 1024 bins between the maximum and minimum data points. The bin containing the most data points below the 50% point is the low bin. The average of all the data points in the low bin is returned as the Low level. If no low bin contains more than 1.25% of the total number of acquired points, then the minimum value is returned by these queries.

Query Syntax	MEASure[SCALar]:VOLTage:LOW? FETCh[:SCALar]:VOLTage:LOW?
Parameters	None
Examples	MEAS : VOLT : LOW? FETC : VOLT : LOW?
Returned Parameters	<NR3>
Related Commands	MEAS:VOLT:HIGH? CALC:REF:LOW

MEASure:VOLTage:MAXimum? FETCh:VOLTage:MAXimum?

Agilent 66312A, 66332A Only

These queries return the maximum output voltage reading from the measurement sample.

Query Syntax	MEASure[:SCALar]:VOLTage:MAXimum? FETCh[:SCALar]:VOLTage:MAXimum?
Parameters	None
Examples	MEAS : VOLT : MAX? FETC : VOLT : MAX?
Returned Parameters	<NR3>
Related Commands	MEAS:VOLT:MIN?

MEASure:VOLTage:MINimum? FETCh:VOLTage:MINimum?

Agilent 66312A, 66332A Only

These queries return the minimum output voltage reading from the measurement sample.

Query Syntax	MEASure[:SCALar]:VOLTage:MINimum? FETCh[:SCALar]:VOLTage:MINimum?
Parameters	None
Examples	MEAS : VOLT : MIN? FETC : VOLT : MIN?
Returned Parameters	<NR3>
Related Commands	MEAS:VOLT:MAX?

SENSe:CURRent:RANGe

This command selects the dc current measurement range. All models have two current measurement ranges:

High Range: 0 through MAX (see Table 4-3)

Low Range: 0 through 0.02 A (all models)

The High range covers the full current measurement capability of the instrument. The Low range measures currents up to a maximum of 20 mA. This increases the low current measurement sensitivity for greater accuracy and resolution. The value that you program with SENSe:CURRent:RANGe must be the maximum current that you expect to measure. The instrument will select the range that gives the best resolution. The crossover value is 20 mA. When queried, the returned value is the maximum current that can be measured on the range that is presently set.

Command Syntax	SENSe:CURRent[:DC]:RANGe[:UPPer]<NRf+>
Parameters	0 through MAX (see table 4-3)
Unit	A (amperes)
*RST Value	MAX (high range)
Examples	SENS:CURR:RANG 4.0
Query Syntax	SENSe:CURRent:RANGe?
Returned Parameters	<NR3>

SENSe:CURRent:DETEctor

Agilent 66312A, 66332A Only

This command lets you select the type of detector used for output current measurements. Two choices for detecting current measurements are available:

- ACDC** This is the preferred choice for all dynamic current measurements. When ACDC is selected, the measured output current includes the current that flows in the instrument's output capacitor. It is especially important to use ACDC detection when measuring pulse or other waveforms with frequency contents greater than several kilohertz.
- DC** Select *DC* only if you are making dc current measurements and you require a dc measurement offset accuracy better than 2mA on the High current measurement range. When DC is selected, the component of output current that is supplied by the instrument's output filter is not sensed. Note that this selection gives inaccurate results on current waveforms with frequency contents greater than several kilohertz.

NOTE: This command only applies to the High current measurement range.

Command Syntax	SENSe:CURRent:DETEctor<detector>
Parameters	ACDC or DC
*RST Value	ACDC
Examples	SENS:CURR:DET ACDC SENS:CURR:DET DC
Query Syntax	SENSe:CURRent:DETEct?
Returned Parameters	<CRD>

SENSe:FUNCTION**Agilent 66312A, 66332A Only**

This command configures the measurement sensor to measure either voltage or current when an acquire trigger is used. The query returns the function setting, either VOLT or CURR.

Command Syntax	SENSe:FUNCTION <function
Parameters	"VOLTage" "CURRent"
Examples	SENS:FUNC "VOLT"
Query Syntax	SENSe:FUNCTION?
Returned Parameters	<SRD>

SENSe:SWEep:OFFSet:POINTs**Agilent 66312A, 66332A Only**

This command defines the offset in a data sweep when an acquire trigger is used. Negative values represent data samples taken prior to the trigger.

Command Syntax	SENSe:SWEep:OFFSet:POINTs <NRf+>
Parameters	-4095 through 2,000,000,000
*RST Value	0
Examples	SENS:SWE:OFFS:POIN -2047
Query Syntax	SENSe:SWEep:OFFSet:POINTs?
Returned Parameters	<NR3>
Related Commands	SENS:SWE:TINT SENS:SWE:POIN MEAS:ARR

SENSe:SWEep:POINTs

This command defines the number of points in a data sweep.

Command Syntax	SENSe:SWEep:POINTs<NRf+>
Parameters	0 through 4096
*RST Value	2048
Examples	SENS:SWE:POIN 1024
Query Syntax	SENSe:SWEep:POINTs?
Returned Parameters	<NR3>
Related Commands	SENS:SWE:TINT SENS:SWE:OFFS MEAS:ARR

SENSe:SWEep:TINTerval

This command defines the time period between samples

Command Syntax	SENSe:SWEep:TINTerval<NRf+>
Parameters	15.6 microseconds through 31200 seconds
*RST Value	15.6 microseconds
Examples	SENS:SWE:TINT 31.2E-6
Query Syntax	SENSe:SWEep:TINTerval?
Returned Parameters	<NR3>
Related Commands	SENS:SWE:POIN SENS:SWE:OFFS MEAS:ARR

SENSe:WINDow

This command sets the window function that is used in output measurement calculations. The following functions can be selected:

- HANNing** A signal conditioning window that reduces errors in dc and rms measurement calculations in the presence of periodic signals such as line ripple. It also reduces jitter when measuring successive pulse waveforms. The Hanning window multiplies each point in the measurement sample by the function \cos^4 . Do not use the Hanning window when measuring single-shot pulse waveforms.
- RECTangular** A window that returns measurement calculations without any signal conditioning. This window may be used for pulse measurements where the exact period of the pulse waveform is known and the measurement interval can be set accordingly using the SENSe:SWEep:TINterval command.

NOTE: Neither window function alters the instantaneous voltage or current data returned in the measurement array.

Command Syntax	SENSe:WINDow[:TYPE] <type>
Parameters	HANNing RECTangular
*RST Value	HANNing
Examples	SENS:WIND RECT
Query Syntax	SENSe:WINDow[:TYPE]?
Returned Parameters	<CRD>

Output Commands

Output commands consist of output and source commands.

Output commands control the output and digital port functions. They also control the output relay on units with Relay Option 760.

Source commands program the actual voltage, current, and digital port output.

OUTPut

This command enables or disables the dc source output. The state of a disabled output is a condition of zero output voltage and a model-dependent minimum source current (see ***RST**). Unless the **NORelay** command is programmed, the **OUTPut** command also controls the output relay on Agilent models 66332A, 6631B, 6632B, 6633B, and 6634B with Relay Option 760. If the **NORelay** command is sent, the output relay state does NOT change.

Command Syntax	OUTPut[:STATe] <bool> [,NORelay]
Parameters	0 OFF 1 ON
*RST Value	0
Examples	OUTP 1 OUTPUT:STATE ON
Query Syntax	OUTPut[:STATe]?
Returned Parameters	<NR1>0 or 1
Related Commands	*RST *RCL *SAV

OUTPut:DFI

This command enables or disables the discrete fault indicator (DFI) output from the dc source.

Command Syntax	OUTPut:DFI[:STATe]<bool>
Parameters	0 1 OFF ON
*RST Value	OFF
Examples	OUTP:DFI 1 OUTP:DFI ON
Query Syntax	OUTPut:DFI[:STATe]?
Returned Parameters	0 1
Related Commands	OUTP:DFI:SOUR

OUTPut:DFI:SOURce

This command selects the source for discrete fault indicator (DFI) events. The choices are:

QUESTIONable	selects the Questionable event summary bit (bit 3 of the Status Byte Register)
OPERation	selects the Operation Event summary bit (bit 7 of the Status Byte Register)
ESB	selects the Standard Event summary bit (bit 5 of the Status Byte Register)
RQS	selects the Request Service bit (bit 6 of the Status Byte Register)
OFF	selects no DFI source

Command Syntax	OUTP:DFI:SOUR<source>
Parameters	QUES OPER ESB RQS OFF
*RST Value	OFF
Examples	OUTP:DFI:SOUR OPER
Query Syntax	OUTPut:DFI:SOUR?
Returned Parameters	<CRD>
Related Commands	OUTP:DFI

OUTPut:PON:STATe

This command selects the power-on state of the dc source. This information is saved in non-volatile memory. The following states can be selected:

- RST** Sets the power-on state to *RST. Refer to the *RST command as described in this chapter for more information.
- RCL0** Sets the power-on state to *RCL 0. Refer to the *RCL command as described in this chapter for more information.

Command Syntax OUTPut:PON:STATe <state>
Parameters RST | RCL0
Examples OUTP: PON: STAT RST
Query Syntax OUTPut:PON:STATe?
Returned Parameters <CRD>
Related Commands *RST *RCL

OUTPut:PROTection:CLEAr

This command clears the latch that disables the output when an OverVoltage, OverCurrent, OverTemperature, Remote Inhibit, or Fuse Status condition is detected. All conditions that generate the fault must be removed before the latch can be cleared. The output is then restored to the state it was in before the fault condition occurred.

Command Syntax OUTPut:PROTection:CLEAr
Parameters None
Examples OUTP: PROT: CLE
Related Commands OUTP:PROT:DEL *RCL *SAV

OUTPut:PROTection:DELAy

This command sets the time between the programming of an output change that produces a constant current condition (CC) and the recording of that condition by the Operation Status Condition register. The delay prevents the momentary changes in status that can occur during reprogramming from being registered as events by the status subsystem. Since the constant current condition is used to trigger overcurrent protection (OCP), this command also delays OCP. Overvoltage protection is not affected by this comand.

Command Syntax OUTPut:PROTection:DELAy <NRf+>
Parameters 0 to 2,147,483.647
Unit seconds
***RST Value** 0.08 (Normal)
Examples OUTPUT: PROTECTION: DELAY 75E-1
Query Syntax OUTPut:PROTection:DELAy?
Returned Parameters <NR3>
Related Commands OUTP:PROT:CLE *RCL *SAV

OUTPut:RELAy

Agilent 66332A, 6632B, 6633B, 6634B, 6611C, 6612C, 6613C, 6614C Only

This command is only valid for units with Relay Option 760, otherwise an error will occur. Programming ON closes the output relay contacts; programming OFF opens them. The relay is controlled independently of the output state. If the dc source is supplying power to a load, that power will appear at the relay contacts during switching.

Command Syntax	OUTPut:RELAy[:STATe]<bool>
Parameters	0 1 OFF ON
*RST Value	0
Examples	OUTP:REL 1 OUTP:REL OFF
Query Syntax	OUTPput:RELAy?
Returned Parameters	0 1
Related Commands	OUTP *RCL *SAV

OUTPut:RELAy:POLarity

Agilent 66332A, 6632B, 6633B, 6634B, 6611C, 6612C, 6613C, 6614C Only

This command is only valid for units with Relay Option 760, otherwise an error will occur. Programming NORMAl causes the output relay polarity to be the same as the dc source output. Programming REVerse causes the relay output polarity to be opposite to that of the dc source output. If OUTPut = ON when either command is sent, the output voltage is set to 0 during the time that the relays are changing polarity.

Command Syntax	OUTPut:RELAy:POLarity<CRD>
Parameters	NORMAl REVerse
*RST Value	NORM
Examples	OUTP:REL:POL NORM
Query Syntax	OUTPput:RELAy:POLarity?
Returned Parameters	NORM REV
Related Commands	OUTP *RCL *SAV

OUTPut:RI:MODE

This command selects the mode of operation of the Remote Inhibit protection. The RI mode is stored in non-volatile memory. The following modes can be selected:

LATCHing	causes a TTL low signal on the INH input to disable the output. The only way to clear the latch is by sending an OUTPut:PROTection:CLEAR command while the INH input is false.
LIVE	allows the INH input to disable the output in a non-latching manner. In other words, the output follows the state of the INH input. When INH is low true, the output is disabled. When INH is high the output is not affected.
OFF	the INH input is disabled.

Command Syntax	OUTPut:RI:MODE <mode>
Parameters	LATCHing LIVE OFF
Examples	OUTP:RI:MODE LIVE
Query Syntax	OUTPut:RI:MODE?
Returned Parameters	<CRD>
Related Commands	OUTP:PROT:CLE

[SOURce:]CURRent

This command sets the immediate current level of the dc source . The immediate level is the current programmed for the output terminals.

Command Syntax	[SOURce]:CURRent[:LEVel][:IMMediate][:AMPLitude]<NRf+>
Parameters	see Table 4-3
Default Suffix	A (amperes)
*RST Value	10% of MAX
Examples	CURR 200 MA CURRENT:LEVEL 200 MA
Query Syntax	[SOURce]:CURRent[:LEVel][:IMMediate][:AMPLitude]?
Returned Parameters	<NR3>
Related Commands	CURR:TRIG

[SOURce:]CURRent:TRIGger

This command sets the pending triggered current level of the dc source . The pending triggered level is a stored current value that is transferred to the output terminals when a trigger occurs. In order for a trigger to occur, the trigger subsystem must be initiated (see the INITiate command in the trigger subsystem).

Command Syntax	[SOURce]:CURRent[:LEVel]:TRIGgered[:AMPLitude]<NRf+>
Parameters	see Table 4-3
Default Suffix	A (amperes)
*RST Value	10% of MAX
Examples	CURR:TRIG 1 CURRENT:LEVEL:TRIGGERED 1
Query Syntax	SOURce]:CURRent[LEVel]:TRIGgered[:AMPLitude]?
Returned Parameters	<NR3>
Related Commands	INIT CURR

[SOURce:]CURRent:PROTection:STATe

This command enables or disables the overcurrent protection (OCP) function. If the dc source overcurrent protection function is enabled and the dc source goes into constant current operation, then the output is disabled and the Questionable Condition status register OC bit is set (see chapter 3 under Programming the Status Registers). Note that the [SOURce:]CURRent command sets the current limit, which determines when the dc source goes into constant current operation. An overcurrent condition can be cleared with the OUTPut:PROTection:CLEar command after the cause of the condition is removed.

NOTE: Use OUTP:PROT:DEL to prevent momentary current limit conditions caused by programmed output changes from tripping the overcurrent protection.

Command Syntax	[SOURce]:CURRent:PROTection:STATe <bool>
Parameters	0 1 OFF ON
*RST Value	OFF
Examples	CURR:PROT:STAT 0 CURRENT:PROTECTION:STATE OFF CURR:PROT:STAT 1 CURRENT:PROTECTION:STATE ON
Query Syntax	Syntax [SOURce]:CURRent:PROTection:STATe?
Returned Parameters	<NR1>0 or 1
Related Commands	OUTP:PROT:CLE *RST

[SOURce:]DIGital:DATA

This command sets and reads the dc source digital control port when that port is configured for Digital I/O operation. The port has three signal pins and a digital ground pin. Pins 1 and 2 are output pins controlled by bits 0 and 1. Pin 3 is controlled by bit 2, and can be programmed to serve either as an input or an output. It normally serves as an output. Bit 2 must be programmed high to use pin 3 as an input. Pin 4 is the digital ground. The query returns the last programmed value in bits 0 and 1 and the value read at pin 3 in bit 2.

Program Value	Bit Configuration			Pin Setting			
	2	1	0	4	3	2	1
0	0	0	0	GND	Output	Lo	Lo
1	0	0	1	GND	Output	Lo	Hi
2	0	1	0	GND	Output	Hi	Lo
3	0	1	1	GND	Output	Hi	Hi
4	1	0	0	GND	Input	Lo	Lo
5	1	0	1	GND	Input	Lo	Hi
6	1	1	0	GND	Input	Hi	Lo
7	1	1	1	GND	Input	Hi	Hi

Command Syntax [SOURce:]DIGital:DATA[:VALue] <NRf>
Parameters 0 to 7
***RST Value** 0
Examples DIG:DATA 7
Query Syntax [SOURce:]DIGital:DATA?
Returned Parameters <NR1>
Related Commands DIG:FUNC

[SOURce:]DIGital:FUNCTION

This command configures the dc source digital control port. The configuration setting is saved in non-volatile memory.

RIDFi Configures the port for Remote Inhibit/Discrete Fault Interrupt operation
DIGio Configures the port for Digital input/output operation (see DIG:DATA)

Command Syntax [SOURce:]DIGital:FUNCTION <CRD>
Parameters RIDFi | DIGio
Examples DIG:FUNC DIG
Query Syntax [SOURce:]DIGital:FUNC?
Returned Parameters <CRD>
Related Commands DIG:DATA

[SOURce:]VOLTage

This command sets the output voltage level of the dc source.

Command Syntax [SOURce:]VOLTage[:LEVel][:IMMediate][:AMPLitude]<NRf+>
Parameters see Table 4-3
Default Suffix V (volts)
***RST Value** 0
Examples VOLT 2 VOLTAGE:LEVEL 200 MV
Query Syntax [SOURce:]VOLTage[:LEVel][:IMMediate][:AMPLitude]?
Returned Parameters <NR3>
Related Commands VOLT:TRIG

[SOURce:]VOLTage:ALC:BANDwidth?**[SOURce:]VOLTage:ALC:BWIDth?**

Agilent 66332A, 6631B, 6632B, 6633B and 6634B Only

These queries return the setting of the output mode switch. The output mode switch is used to connect or disconnect the the output capacitor located inside the unit. The returned value is 15,000 if the switch is set to Normal and 60,000 if the switch is set to Fast.

Query Syntax	[SOURce]:VOLTage:ALC:BANDwidth?
	[SOURce]:VOLTage:ALC:BWIDth?
Examples	VOLT:ALC: BAND? VOLTAGE:ALC:BWIDth?
Returned Parameters	<NR3>

[SOURce:]VOLTage:TRIGger

This command sets the pending triggered voltage level of the dc source. The pending triggered level is a stored voltage value that is transferred to the output terminals when a trigger occurs. In order for a trigger to occur, the trigger subsystem must be initiated (see the INITiate command in the trigger subsystem).

Command Syntax	[SOURce][:VOLTage[:LEVel]:TRIGgered[:AMPLitude]<NRf+>
Parameters	see Table 4-3
Default Suffix	V (volts)
*RST Value	0
Examples	VOLT:TRIG 20 VOLTAGE:LEVEL:TRIGGERED 20
Query Syntax	[SOURce]:VOLTage[LEVel]:TRIGgered[:AMPLitude]?
Returned Parameters	<NR3>
Related Commands	VOLT *RST

[SOURce:]VOLTage:PROTection

This command sets the overvoltage protection (OVP) level of the dc source. If the output voltage exceeds the OVP level, then the dc source output is disabled and the Questionable Condition status register OV bit is set (see chapter 3 under Programming the Status Registers). An overvoltage condition can be cleared with the OUTP:PROT:CLE command after the condition that caused the OVP trip is removed. The OVP always trips with zero delay and is unaffected by the OUTP:PROT:DEL command.

Command Syntax	[SOURce]:VOLTage:PROTection[:LEVel]<NRf+>
Parameters	see Table 4-3
Default Suffix	V (volts)
*RST Value	MAX
Examples	VOLT:PROT 21.5 VOLT:PROT:LEV MAX
Query Syntax	[SOURce]:VOLTage:PROTection[:LEVel]?
Returned Parameters	<NR3>
Related Commands	OUTP:PROT:CLE OUTP:PROT:DEL

Status Commands

Status commands program the dc source status registers. The dc source has three groups of status registers; Operation, Questionable, and Standard Event. The Standard Event group is programmed with Common commands as described later in this section. The Operation and Questionable status groups each consist of the Condition, Enable, and Event registers and the NTR and PTR filters. Chapter 3 under "Programming the Status Registers" explains how to read specific register bits and use the information they return.

Common commands also perform status functions. The following common commands are discussed in this section: *CLS *ESE *SR? *OPC *PSC *SRE *STB *WAI.

STATus:PRESet

This command sets all defined bits in the Status Subsystem PTR registers and clears all bits in the subsystem NTR and Enable registers.

Command Syntax STATus:PRESet
Parameters None
Examples STAT: PRES STATUS: PRESET

Table 4-4. Bit Configuration of Operation Status Registers

Bit Position	15-12	11	10	9	8	7-6	5	4-1	0
Bit Name	not used	CC-	CC+	not used	CV	not used	WTG	not used	CAL
Bit Weight		2048	1024		256		32		1

CAL = The dc source is computing new calibration constants.
 WTG = The dc source is waiting for a trigger.
 CV = The dc source is operating in constant voltage mode.
 CC+ = The dc source is operating in constant current mode.
 CC = The dc source is operating in negative constant current mode.

STATus:OPERation?

This query returns the value of the Operation Event register. The Event register is a read-only register which holds (latches) all events that are passed by the Operation NTR and/or PTR filter. Reading the Operation Event register clears it.

Query Syntax STATus:OPERtion[:EVENT]?
Parameters None
Returned Parameters <NR1>(Register Value)
Examples STAT: OPER? STATUS: OPERATIONAL: EVENT?
Related Commands *CLS STAT:OPER:NTR STAT:OPER:PTR

STATus:OPERation:CONDition?

This query returns the value of the Operation Condition register. That is a read-only register which holds the real-time (unlatched) operational status of the dc source .

Query Syntax STATus:OPERation:CONDition?
Parameters None
Examples STAT: OPER: COND? STATUS: OPERATION: CONDITION?
Returned Parameters <NR1> (register value)

STATus:OPERation:ENABLE

This command and its query set and read the value of the Operational Enable register. This register is a mask for enabling specific bits from the Operation Event register to set the operation summary bit (OPER) of the Status Byte register. This bit (bit 7) is the logical OR of all the Operational Event register bits that are enabled by the Status Operation Enable register.

Command Syntax	STATus:OPERation:ENABLE<NRf>	
Parameters	0 to 32727	
Preset Value	0	
Examples	STAT:OPER:ENAB 1312	STAT:OPER:ENAB 1
Query Syntax	STATUS:OPERATION:ENABLE?	
Returned Parameters	<NR1> (register value)	
Related Commands	STAT:OPER:EVEN	

STATus:OPERation:NTR

STATus:OPERation:PTR

These commands set or read the value of the Operation NTR (Negative-Transition) and PTR (Positive-Transition) registers. These registers serve as polarity filters between the Operation Enable and Operation Event registers to cause the following actions:

- ◆ When a bit in the Operation NTR register is set to 1, then a 1-to-0 transition of the corresponding bit in the Operation Condition register causes that bit in the Operation Event register to be set.
- ◆ When a bit of the Operation PTR register is set to 1, then a 0-to-1 transition of the corresponding bit in the Operation Condition register causes that bit in the Operation Event register to be set.
- ◆ If the same bits in both NTR and PTR registers are set to 1, then any transition of that bit at the Operation Condition register sets the corresponding bit in the Operation Event register.
- ◆ If the same bits in both NTR and PTR registers are set to 0, then no transition of that bit at the Operation Condition register can set the corresponding bit in the Operation Event register.

Command Syntax	STATus:OPERtion:NTRansition<NRf>	
	STATus:OPERtion:PTRansition<NRf>	
Parameters	0 to 32727	
Preset Value	NTR register = 0; PTR register = 32727	
Examples	STAT:OPER:NTR 32	STAT:OPER:PTR 1312
Query Syntax	STAT:OPER:NTR?	STAT:OPER:PTR?
Returned Parameters	<NR1> (register value)	
Related Commands	STAT:OPER:ENAB	

Table 4-5. Bit Configuration of Questionable Status Registers

Bit Position	15	14	13-11	10	9	8-5	4	3	2	1	0
Bit Name	not used	Meas Ovid	not used	Unreg	RI	not used	OT	not used	FS	OCP	OV
Bit Weight		16384		1024	512		16		4	2	1

OV = overvoltage protection has tripped
 OCP = overcurrent protection has tripped
 FS = the fuse is blown
 OT = overtemperature protection has tripped
 RI = remote inhibit is active
 Unreg = output is unregulated
 Meas Ovid = measurement overload

STATus:QUESTIONable?

This query returns the value of the Questionable Event register. The Event register is a read-only register which holds (latches) all events that are passed by the Questionable NTR and/or PTR filter. Reading the Questionable Event register clears it.

Query Syntax STATus:QUESTIONable[:EVENT]?
Parameters None
Examples STAT:QUES? STATUS:QUESTIONABLE:EVENT?
Returned Parameters <NR1> (register value)
Related Commands *CLS STAT:QUES:ENAB
 STAT:QUES:NTR STAT:QUES:PTR

STATus:QUESTIONable:CONDition?

This query returns the value of the Questionable Condition register. That is a read-only register which holds the real-time (unlatched) questionable status of the dc source.

Query Syntax STATus:QUESTIONable:CONDition?
Parameters None
Examples STAT:QUES:COND? STATUS:QUESTIONABLE:CONDITION?
Returned Parameters <NR1> (register value)

STATus:QUESTIONable:ENABLE

This command and its query set and read the value of the Questionable Enable register. This register is a mask for enabling specific bits from the Questionable Event register to set the questionable summary bit (QUES) of the Status Byte register. This bit (bit 3) is the logical OR of all the Questionable Event register bits that are enabled by the Questionable Status Enable register..

Command Syntax STATus:QUESTIONable:ENABLE<NRf>
Parameters 0 to 32767
Preset Value 0
Examples STAT:QUES:ENAB 20 STAT:QUES:ENAB 16
Query Syntax STATus:QUESTIONable:ENABLE?
Returned Parameters <NR1> (register value)
Related Commands STAT:QUES?

STATus:QUESTIONable:NTR
STATus:QUESTIONable:PTR

These commands allow you to set or read the value of the Questionable NTR (Negative-Transition) and PTR (Positive-Transition) registers. These registers serve as polarity filters between the Questionable Enable and Questionable Event registers to cause the following actions:

- ◆ When a bit of the Questionable NTR register is set to 1, then a 1-to-0 transition of the corresponding bit of the Questionable Condition register causes that bit in the Questionable Event register to be set.
- ◆ When a bit of the Questionable PTR register is set to 1, then a 0-to-1 transition of the corresponding bit in the Questionable Condition register causes that bit in the Questionable Event register to be set.
- ◆ If the same bits in both NTR and PTR registers are set to 1, then any transition of that bit at the Questionable Condition register sets the corresponding bit in the Questionable Event register.
- ◆ If the same bits in both NTR and PTR registers are set to 0, then no transition of that bit at the Questionable Condition register can set the corresponding bit in the Questionable Event register.

Command Syntax	STATus:QUESTIONable:NTRansition<NRf> STATus:QUESTIONable:PTRansition<NRf>
Parameters	0 to 32727
Preset Value	NTR register = 0; PTR register = 32727
Examples	STAT:QUES:NTR 16 STATUS:QUESTIONABLE:PTR 512
Query Syntax	STAT:QUES:NTR?STAT:QUES:PTR?
Returned Parameters	<NR1>(Register value)
Related Commands	STAT:QUES:ENAB

***CLS**

This command causes the following actions (see chapter 3 under Programming the Status Registers, for the descriptions of all registers):

- ◆ Clears the following registers:
 - Standard Event Status
 - Operation Status Event
 - Questionable Status Event
 - Status Byte
- ◆ Clears the Error Queue
- ◆ If *CLS immediately follows a program message terminator (<NL>), then the output queue and the MAV bit are also cleared.

Command Syntax	*CLS
Parameters	None

***ESE**

This command programs the Standard Event Status Enable register bits. The programming determines which events of the Standard Event Status Event register (see *ESR?) are allowed to set the ESB (Event Summary Bit) of the Status Byte register. A "1" in the bit position enables the corresponding event. All of the enabled events of the Standard Event Status Event Register are logically ORed to cause the Event Summary Bit (ESB) of the Status Byte Register to be set. The query reads the Standard Event The query reads the Standard Event Status Enable register.

Table 4-6. Bit Configuration of Standard Event Status Enable Register

Bit Position	7	6	5	4	3	2	1	0
Bit Name	PON	0	CME	EXE	DDE	QUE	0	OPC
Bit Weight	128	64	32	16	8	4	2	1
PON = Power-on has occurred CME = Command error EXE = Execution error				DDE = Device-dependent error QUE = Query error OPC = Operation complete				

Command Syntax *ESE <NRf>
Parameters 0 to 255
Power-On Value (See *PSC)
Examples *ESE 129
Query Syntax *ESE?
Returned Parameters <NR1>(Register value)
Related Commands *ESR? *PSC *STB?

CAUTION: If *PSC is programmed to 0, the *ESE command causes a write cycle to nonvolatile memory. Nonvolatile memory has a finite maximum number of write cycles. Programs that repeatedly cause write cycles to nonvolatile memory can eventually exceed the maximum number of write cycles and cause the memory to fail.

***ESR?**

This query reads the Standard Event Status Event register. Reading the register clears it. The bit configuration is the same as the Standard Event Status Enable register (see *ESE).

Query Syntax *ESR?
Parameters None
Returned Parameters <NR1>(Register binary value)
Related Commands *CLS *ESE *ESE? *OPC

***OPC**

This command causes the instrument to set the OPC bit (bit 0) of the Standard Event Status register when the has completed all pending operations. (See *ESE for the bit configuration of the Standard Event Status register.) *Pending operations* are complete when:

- ◆ all commands sent before *OPC have been executed. This includes overlapped commands. Most commands are sequential and are completed before the next command is executed. Overlapped commands are executed in parallel with other commands. Commands that affect output voltage, current or state, relays, and trigger actions are overlapped with subsequent commands sent to the dc source. The *OPC command provides notification that all overlapped commands have been completed.
- ◆ all triggered actions are completed

4 - Language Dictionary

*OPC does not prevent processing of subsequent commands, but bit 0 will not be set until all pending operations are completed.

*OPC? causes the instrument to place an ASCII "1" in the Output Queue when all pending operations are completed. Unlike *OPC, *OPC? prevents processing of all subsequent commands. It is intended to be used at the end of a command line so that the application program can then monitor the bus for data until it receives the "1" from the dc source Output Queue.

Command Syntax	*OPC
Parameters	None
Query Syntax	*OPC?
Returned Parameters	<NR1> 1
Related Commands	*OPC *TRIG *WAI

*PSC

This command controls the automatic clearing at power-on of the Service Request Enable and the Standard Event Status Enable registers

***PSC ON | 1** causes these registers to be cleared at power-on. This prevents a PON event from generating SRQ at power-on.

***PSC OFF | 0** causes the contents of the Standard Event Enable and Service Request Enable registers to be saved in nonvolatile memory and recalled at power-on. This allows a PON event to generate SRQ at power-on.

The query returns the current state of *PSC.

Command Syntax	*PSC <Bool>
Parameters	0 1 OFF ON
Example	*PSC 0 *PSC 1
Query Syntax	*PSC?
Returned Parameters	<NR1>0 1
Related Commands	*ESE *SRE

CAUTION: *PSC causes a write cycle to nonvolatile memory. Nonvolatile memory has a finite maximum number of write cycles. Programs that repeatedly cause write cycles to nonvolatile memory can eventually exceed the maximum number of write cycles and cause the memory to fail.

*SRE

This command sets the condition of the Service Request Enable Register. This register determines which bits from the Status Byte Register (see *STB for its bit configuration) are allowed to set the Master Status Summary (MSS) bit and the Request for Service (RQS) summary bit. A 1 in any Service Request Enable Register bit position enables the corresponding Status Byte Register bit and all such enabled bits then are logically ORed to cause Bit 6 of the Status Byte Register to be set.

When the controller conducts a serial poll in response to SRQ, the RQS bit is cleared, but the MSS bit is not. When *SRE is cleared (by programming it with 0), the dc source cannot generate an SRQ to the controller.

The query returns the current state of *SRE.

Command Syntax *SRE <NRf>
Parameters 0 to 255
Power-on Value see *PSC
Example *SRE 20
Query Syntax *SRE?
Returned Parameters <NR1> (register binary value)
Related Commands *ESE *ESR *PSC

CAUTION: If *PSC is programmed to 0, the *SRE command causes a write cycle to nonvolatile memory. Nonvolatile memory has a finite maximum number of write cycles. Programs that repeatedly cause write cycles to nonvolatile memory can eventually exceed the maximum number of write cycles and cause the memory to fail.

*STB?

This query reads the Status Byte register, which contains the status summary bits and the Output Queue MAV bit. Reading the Status Byte register does not clear it. The input summary bits are cleared when the appropriate event registers are read. The MAV bit is cleared at power-on, by *CLS' or when there is no more response data available.

A serial poll also returns the value of the Status Byte register, except that bit 6 returns Request for Service (RQS) instead of Master Status Summary (MSS). A serial poll clears RQS, but not MSS. When MSS is set, it indicates that the has one or more reasons for requesting service.

Table 4-7. Bit Configuration of Status Byte Register

Bit Position	7	6	5	4	3	2	1	0
Bit Name	OPER	MSS (RQS)	ESB	MAV	QUES	0	0	0
Bit Weight	128	64	32	16	8	4	2	1
ESB = Event status byte summary MAV = Message available MSS = Master status summary				OPER = Operation status summary QUES = Questionable status summary RQS = Request for service				

Query Syntax *STB?
Returned Parameters <NR1>(Register binary value)

*WAI

This command instructs the dc source not to process any further commands until all pending operations are completed. "Pending operations" are as defined under the *OPC command. *WAI can be aborted only by sending the dc source an GPIB DCL (Device Clear) command.

Command Syntax WAI?
Parameters None
Related Commands *OPC*OPC?

System Commands

System commands consist of system, display, and common commands.

System commands commands control system functions that are not directly related to output control or measurement functions.

Display commands control the front panel display of the .

Common commands also perform system functions. The following common commands are discussed in this section: *IDN? *OPT? *RCL *RST *SAV *TST?.

DISPlay

This command turns the front panel display on or off. When off, the front panel display is blank. The display annunciators are not affected by this command.

Command Syntax	DISPlay[:WINDow][:STATe] <bool>
Parameters	0 1 OFF ON
*RST Value	ON
Examples	DISP ON DISPLAY:STATE ON
Query Syntax	DISPlay[:WINDow][:STATe]?
Returned Parameters	<NR1> 0 or 1
Related Commands	DISP:MODE DISP:TEXT *RST

DISPlay:MODE

Switches the display between its normal instrument functions and a mode in which it displays text sent by the user. Text messages are defined with the DISPlay:TEXT command.

Command Syntax	DISPlay[:WINDow]:MODE NORMal TEXT
Parameters	<CRD>NORMal TEXT
*RST Value	NORM
Examples	DISP:MODE NORM DISPLAY:MODE TEXT
Query Syntax	DISPlay[:WINDow]:MODE?
Returned Parameters	<CRD> NORMAL or TEXT
Related Commands	DISP DISP:TEXT *RST

DISPlay:TEXT

This command sends character strings to the display when the display mode is set to TEXT. The character string is case-sensitive and must be enclosed in either single (') or double (") quotes. The display is capable of showing up to 14 characters. Strings exceeding 14 characters will be truncated.

Command Syntax	DISPlay[:WINDow]:TEXT [:DATA] <display_string>
Parameters	<display string>
*RST Value	null string
Examples	DISP:TEXT "DEFAULT_MODE" DISPLAY:WINDOW:TEXT:DATA '533.2E-1VOLTS'
Query Syntax	DISPlay[:WINDow]:TEXT?
Returned Parameters	<STR>(Last programmed text string)
Related Commands	DISP DISP:MODE

SYSTem:ERRor?

This query returns the next error number followed by its corresponding error message string from the remote programming error queue. The queue is a FIFO (first-in, first-out) buffer that stores errors as they occur. As it is read, each error is removed from the queue. When all errors have been read, the query returns 0,NO ERROR. If more errors are accumulated than the queue can hold, the last error in the queue will be -350,TOO MANY ERRORS (see Appendix C for other error codes).

You can use the front panel Error key to read errors from the queue. Errors generated at the front panel are not put into the queue but appear immediately on the display.

Query Syntax	SYSTem:ERRor?
Parameters	(None)
Returned Parameters	<NR1>, <SRD>
Examples	SYST:ERR? SYSTem:ERRor?

SYSTem:LANGuage

This command switches the instrument between its SCPI command language and its compatibility language. The compatibility language is provided for emulation of older dc source systems and is described in Appendix B. Sending the command causes:

- ◆ The selected language to become active and to be stored in nonvolatile memory.
- ◆ The to reset to its power-on state.

If the dc source is shut off, it will resume operation in the last-selected language when power is restored. Note that this command and query can be used regardless of the language that is presently selected.

Command Syntax	SYSTem:LANGuage<string>
Parameters	SCPI COMPatibility
Power-on Value	<i>last selected language</i>
Example	SYST:LANG SCPI SYSTem:LANGuage COMPatibility
Query Syntax	SYSTem:LANGuage?
Returned Parameters	<CRD>

SYSTem:VERSion?

This query returns the SCPI version number to which the complies. The returned value is of the form YYYY.V, where YYYY represents the year and V is the revision number for that year.

Query Syntax	SYSTem:VERSion?
Parameters	(none)
Returned Parameters	<NR2>
Examples	SYST:VERS? SYSTem:VERSion?

SYSTem:LOCal

For RS-232 Operation Only

This command places the dc source in local mode during RS-232 operation. The front panel keys are functional.

Command Syntax	SYSTem:LOCal
Parameters	None
Example	SYST:LOC
Related Commands	SYST:REM SYST:RWL

SYSTem:REMOte

For RS-232 Operation Only

This command places the dc source in remote mode during RS-232 operation. This disables all front panel keys except the Local key. Pressing the Local key while in the remote state returns the front panel to the local state.

Command Syntax	SYSTem:REMOte
Parameters	None
Example	SYST:REM
Related Commands	SYST:LOC SYST:RWL

SYSTem:RWLock

For RS-232 Operation Only

This command places the dc source in remote mode during RS-232 operation. All front panel keys including the Local key are disabled. Use SYSTem:LOCAl to return the front panel to the local state.

Command Syntax	SYSTem:RWLock
Parameters	None
Example	SYST:RWL
Related Commands	SYST:REM SYST:LOC

*IDN?

This query requests the dc source to identify itself. It returns a string composed of four fields separated by commas.

Query Syntax	*IDN?	Field	Information
Returned Parameters	<AARD>	Agilent Technologies xxxxxA nnnnA-nnnnn <A>.xx.xx	Manufacturer model number followed by a letter suffix 10-character serial number or 0 Revision levels of firmware.
Example	AGILENT,66312A,0,A.00.01		

***OPT?**

This query requests the dc source to identify any options that are installed. Options are identified by number A 0 indicates no options are installed.

Query Syntax *OPT?
Returned Parameters <AARD>

***RCL**

WARNING: Recalling a previously stored state may place hazardous voltages at the dc source output.

This command restores the dc source to a state that was previously stored in memory with the *SAV command to the specified location. All states are recalled with the following exceptions:

- ◆ the trigger system is set to the Idle state by an implied ABORt command (this cancels any uncompleted trigger actions)
- ◆ the calibration function is disabled by setting CAL:STATe to OFF

NOTE: The device state stored in location 0 is automatically recalled at power turn-on when the OUTPut:PON:STATe is set to RCL0.

Command Syntax *RCL <NRf>
Parameters 0 | 1 | 2 | 3
Example *RCL 3
Related Commands *PSC *RST *SAV

***RST**

This command resets the to a factory-defined state as defined in the following table. *RST also forces an ABORt command.

Command Syntax *RST
Parameters None
Related Commands *PSC *SAV

Table 4-8. *RST Settings

CAL:STAT	OFF	[SOUR:]CURR	10% of MAX*
DIG:DATA	0	[SOUR:]CURR:TRIG	10% of MAX*
DISP:STAT	ON	[SOUR:]CURR:PROT:STAT	OFF
DISP:MODE	NORM	[SOUR:]LIST:COUN	0
DISP:TEXT		[SOUR:]VOLT	0
INIT:CONT	OFF	[SOUR:]VOLT:TRIG	0
OUTP	OFF	[SOUR:]VOLT:PROT	MAX*
OUTP:DFI	OFF	TRIG:ACQ:COUN:CURR	1
OUTP:DFI:SOUR	OFF	TRIG:ACQ:COUN:VOLT	1
OUTP:PROT:DEL	.08 Norm; .008 Fast	TRIG:ACQ:HYST:CURR	0
OUTP:REL	OFF	TRIG:ACQ:HYST:VOLT	0
OUTP:REL:POL	NORM	TRIG:ACQ:LEV:CURR	MAX*
SENS:CURR:RANG	MAX	TRIG:ACQ:LEV:VOLT	MAX*
SENS:CURR:DET	ACDC	TRIG:ACQ:SLOP:CURR	POS
SENS:FUNC	VOLT	TRIG:ACQ:SLOP:VOLT	POS
SENS:SWE:OFFS:POIN	0	TRIG:ACQ:SOUR	INTERNAL
SENS:SWE:POIN	2048	TRIG:TRAN:SOUR	BUS
SENS:SWE:TINT	15.6 μ s		

* Maximum values are model-dependent. Refer to Table 4-3.

*SAV

This command stores the present state of the dc source to the specified location in non-volatile memory. Up to 4 states can be stored. If a particular state is desired at power-on, it should be stored in location 0. It will then be automatically recalled at power turn-on if OUTPUT:PON:STATE is set to RCL0. *RCL retrieves instrument states.

Command Syntax *SAV <NRf>
Parameters 0 | 1 | 2 | 3
Example *SAV 3
Related Commands *RCL *RST

CAUTION: *SAV causes a write cycle to nonvolatile memory. Nonvolatile memory has a finite maximum number of write cycles. Programs that repeatedly cause write cycles to nonvolatile memory can eventually exceed the maximum number of write cycles and cause the memory to fail.

*TST?

This query causes the to do a self-test and report any errors. 0 indicates that the dc source passed self-test. 1 indicates that one or more tests failed. Selftest errors are written to the error queue (see Appendix C).

Query Syntax TST?
Returned Parameters <NR1>

Trigger Commands

Trigger commands consist of trigger and initiate commands.

Trigger commands control the remote triggering of the dc source . Trigger commands (and Initiate commands) are referenced either by name or by number. The correspondence between names and numbers is:

Sequence Number	Sequence Name	Description
1 (the default)	TRANSient	Output transient trigger sequence
2	ACQuire	Measurement acquire trigger sequence

Initiate commands initialize the trigger system.

ABORt

This command cancels any trigger actions presently in process. Pending trigger levels are reset to their corresponding immediate values. ABORt also resets the WTG bit in the Operation Condition Status register (see chapter 3 under Programming the Status Registers). If INITiate:CONTInuous ON has been programmed, the trigger subsystem initiates itself immediately after ABORt, thereby setting WTG. ABORt is executed at power turn on and upon execution of *RCL or RST.

Command Syntax	ABORt
Parameters	None
Examples	ABOR
Related Commands	INIT *RST *TRG TRIG

INITiate:SEQuence

INITiate:NAME

INIT:SEQ2 or INIT:NAME ACQ applies to Agilent 66312A, 66332A Only

INITiate commands control the initiation of both output and measurement triggers. When a trigger is enabled, an event on a selected trigger source causes the specified triggering action to occur. If the trigger subsystem is not enabled, all trigger commands are ignored.

Command Syntax	INITiate[:IMMediate]:SEQuence[1 2] INITiate[:IMMediate]:NAME<name>
Parameters	For INIT:NAME TRANSient ACQuire
Examples	INIT:SEQ2 INIT:NAME TRAN
Related Commands	ABOR INIT:CONT TRIG TRIG:SEQ:DEF *TRG

INITiate:CONTInuous:SEQuence1

INITiate:CONTInuous:NAME

These commands control the output transient trigger system.

1 or ON continuously initiates the output trigger system..
0 or OFF turns off continuous triggering. In this state, the output trigger system must be initiated for each trigger using INITiate:SEQuence.

Command Syntax	INITiate:CONTInuous:SEQuence1<bool> INITiate:CONTInuous:NAME TRANSient,<bool>
Parameters	0 1 OFF ON
Examples	INIT:CONT:SEQ ON INIT:CONT:NAME TRAN, 1
Related Commands	ABOR INIT TRIG TRIG:SEQ:DEF *TRG

TRIGger

When the transient trigger subsystem is initiated, this command generates a trigger signal. The trigger will then:

1. Initiate a pending level change as specified by CURRent:TRIGger or VOLTage:TRIGger.
2. Clear the WTG bit in the Status Operation Condition register after both transient and acquire trigger sequences have completed. (WTG is the logical-or of both transient and acquire sequences.)
3. If INITiate:CONTInuous ON has been programmed, the trigger subsystem is immediately re-enabled for subsequent triggers. As soon as it is cleared, the WTG bit is again set to 1.

Command Syntax	TRIGger[:SEQuence1][:IMMediate]
	TRIGger[:TRANsient][:IMMediate]
Parameters	None
Examples	TRIG TRIG:IMM
Related Commands	ABOR CURR:TRIG INIT *TRG VOLT:TRIG

TRIGger:SOURce

This command is included for completeness. It selects the trigger source for transient triggers. Since BUS is the only trigger source for transient triggers, this command does not need to be used.

BUS GPIB device, *TRG, or <GET> (Group Execute Trigger)

Command Syntax	TRIGger[:SEQuence1]:SOURce<source>
	TRIGger[:TRANsient]:SOURce<source>
Parameters	BUS
*RST Value	BUS
Examples	TRIG:SOUR BUS
Query Syntax	TRIGger[:SEQuence1]:SOURce?
	TRIGger[:TRANsient]:SOURce?
Returned Parameters	<CRD>

TRIGger:SEQuence2

TRIGger:ACQuire

Agilent 66312A, 66332A Only

When the trigger subsystem is initiated, these commands generate a measurement trigger signal. The measurement trigger causes the dc source to measure the output voltage and current and store the results in a buffer.

Command Syntax	TRIGger:SEQuence2[:IMMediate]
	TRIGger:ACQuire[:IMMediate]
Parameters	None
Examples	TRIG:SEQ2 TRIG:ACQ
Related Commands	TRIG:SOUR TRIG:SEQ2:DEF TRIG:SEQ2:COUN
	TRIG:SEQ2:LEV:VOLT TRIG:SEQ2:SLOP:CURR

TRIGger:SEquence2:COUNT:CURRent TRIGger:ACQuire:COUNT:CURRent

Agilent 66312A, 66332A Only

This command sets up a successive number of triggers for measuring current data. With this command, the trigger system needs to be initialized only once at the start of the acquisition period. After each completed measurement, the instrument waits for the next valid trigger condition to start another measurement. This continues until the count has completed.

Command Syntax	TRIGger:SEquence2:COUNT:CURRent<NRf+> TRIGger:ACQuire:COUNT:CURRent<NRf+>
Parameters	1 to 100
*RST Value	1
Examples	TRIG:SEQ2:COUN:CURR 5 TRIG:ACQ:COUN:CURR 1
Query Syntax	TRIGger:SEquence2:COUNT:CURRent? TRIGger:ACQuire:COUNT:CURRent?
Returned Parameters	<NR3>
Related Commands	TRIG:SEQ2 TRIG:ACQ

TRIGger:SEquence2:COUNT:VOLTage TRIGger:ACQuire:COUNT:VOLTage

Agilent 66312A, 66332A Only

This command sets up a successive number of triggers for measuring voltage data. With this command, the trigger system needs to be initialized only once at the start of the acquisition period. After each completed measurement, the instrument waits for the next valid trigger condition to start another measurement. This continues until the count has completed.

Command Syntax	TRIGger:SEquence2:COUNT:VOLTage<NRf+> TRIGger:ACQuire:COUNT:VOLTage<NRf+>
Parameters	1 to 100
*RST Value	1
Examples	TRIG:SEQ2:COUN:VOLT 5 TRIG:ACQ:COUN:VOLT 1
Query Syntax	TRIGger:SEquence2:COUNT:VOLTage? TRIGger:ACQuire:COUNT:VOLTage?
Returned Parameters	<NR3>
Related Commands	TRIG:SEQ2 TRIG:ACQ

TRIGger:SEQuence2:HYSTeresis:CURRent TRIGger:ACQuire:HYSTeresis:CURRent

Agilent 66312A, 66332A Only

This command defines a band around the trigger level through which the signal must pass before an internal measurement can occur. The band limit above and below the trigger level is one half of the hysteresis value added to or subtracted from the trigger level.

For a positive trigger to occur, the excursion of an output waveform in the positive direction must start below the lower hysteresis band limit and pass through the upper hysteresis band limit. For a negative trigger to occur, the excursion of an output waveform in the negative direction must start above the upper hysteresis band limit and pass through the lower hysteresis band limit.

Command Syntax	TRIGger:SEQuence2:HYSTeresis:CURRent<NRf+> TRIGger:ACQuire:HYSTeresis:CURRent<NRf+>
Parameters	0 to MAX (see table 4-3)
Unit	A (amperes)
*RST Value	0
Examples	TRIG:SEQ2:HYST:CURR 0.5 TRIG:ACQ:HYST:CURR 0.5
Query Syntax	TRIGger:SEQuence2:HYSTeresis:CURRent? TRIGger:ACQuire:HYSTeresis:CURRent?
Returned Parameters	<NR3>
Related Commands	TRIG:SEQ2:HYST:VOLT TRIG:SEQ2:LEV:CURR

TRIGger:SEQuence2:HYSTeresis:VOLTagE TRIGger:ACQuire:HYSTeresis:VOLTagE

Agilent 66312A, 66332A Only

This command defines a band around the trigger level through which the signal must pass before an internal measurement can occur. The band limit above and below the trigger level is one half of the hysteresis value added to or subtracted from the trigger level.

For a positive trigger to occur, the excursion of an output waveform in the positive direction must start below the lower hysteresis band limit and pass through the upper hysteresis band limit. For a negative trigger to occur, the excursion of an output waveform in the negative direction must start above the upper hysteresis band limit and pass through the lower hysteresis band limit.

Command Syntax	TRIGger:SEQuence2:HYSTeresis:VOLTagE<NRf+> TRIGger:ACQuire:HYSTeresis:VOLTagE<NRf+>
Parameters	0 to MAX (see table 4-3)
Unit	V (volts)
*RST Value	0
Examples	TRIG:SEQ2:HYST:VOLT 2 TRIG:ACQ:HYST:VOLT 2
Query Syntax	TRIGger:SEQuence2:HYSTeresis:VOLTagE? TRIGger:ACQuire:HYSTeresis:VOLTagE?
Returned Parameters	<NR3>
Related Commands	TRIG:SEQ2:HYST:CURR TRIG:SEQ2:LEV:VOLT

TRIGger:SEQuence2:LEVel:CURRent TRIGger:ACQuire:LEVel:CURRent

Agilent 66312A, 66332A Only

This command sets the trigger level for internally triggered current measurements. A positive current trigger occurs when the current level changes from a value less than the lower hysteresis band limit to a value greater than the upper hysteresis band limit. Similarly, a negative current trigger occurs when the current level changes from a value greater than the upper hysteresis band limit to a value less than the lower hysteresis band limit.

Command Syntax	TRIGger:SEQuence2:LEVel:CURRent<NRf+> TRIGger:ACQuire:LEVel:CURRent<NRf+>
Parameters	0 to MAX (see table 4-3)
Unit	A (amperes)
*RST Value	0
Examples	TRIG:SEQ2:LEV:CURR 5 TRIG:ACQ:LEV:CURR MAX TRIG:ACQ:LEV 2
Query Syntax	TRIGger:SEQuence2:LEVel:CURRent? TRIGger:ACQuire:LEVel:CURRent?
Returned Parameters	<NR3>
Related Commands	TRIG:SEQ2:LEV:VOLT TRIG:SEQ2:HYST:CURR

TRIGger:SEQuence2:LEVel:VOLTage TRIGger:ACQuire:LEVel:VOLTage

Agilent 66312A, 66332A Only

This command sets the trigger level for internally triggered voltage measurements. A positive voltage trigger occurs when the voltage level changes from a value less than the lower hysteresis band limit to a value greater than the upper hysteresis band limit. Similarly, a negative voltage trigger occurs when the voltage level changes from a value greater than the upper hysteresis band limit to a value less than the lower hysteresis band limit.

Command Syntax	TRIGger:SEQuence2:LEVel:VOLTage<NRf+> TRIGger:ACQuire:LEVel:VOLTage<NRf+>
Parameters	0 to MAX (see table 4-3)
Unit	V (volts)
*RST Value	0
Examples	TRIG:SEQ2:LEV:VOLT 5 TRIG:ACQ:LEV:VOLT MAX TRIG:ACQ:LEV 2
Query Syntax	TRIGger:SEQuence2:LEVel:VOLTage? TRIGger:ACQuire:LEVel:VOLTage?
Returned Parameters	<NR3>
Related Commands	TRIG:SEQ2:LEV:CURR TRIG:SEQ2:HYST:VOLT

TRIGger:SEquence2:SLOPe:CURRent
TRIGger:ACQuire:SLOPe:CURRent

Agilent 66312A, 66332A Only

This command sets the slope of an internally triggered current measurement.

- POSitive** triggering occurs on the rising edge.
- NEGative** triggering occurs on the falling edge.
- EITHer** triggering occurs on either edge.

Command Syntax	TRIGger:SEquence2:SLOPe:CURRent<slope> TRIGger:ACQuire:SLOPe:CURRent<slope>
Parameters	EITHer POSitive NEGative
*RST Value	EITHer
Examples	TRIG:SEQ2:SLOP:CURR POS TRIG:ACQ:SLOP:CURR EITH
Query Syntax	TRIGger:SEquence2:SLOPe:CURRent? TRIGger:ACQuire:SLOPe:CURRent?
Returned Parameters	<CRD>
Related Commands	TRIG:SEQ2:SLOP:VOLT

TRIGger:SEquence2:SLOPe:VOLTage
TRIGger:ACQuire:SLOPe:VOLTage

Agilent 66312A, 66332A Only

This command sets the slope of an internally triggered voltage measurement.

- POSitive** triggering occurs on the rising edge.
- NEGative** triggering occurs on the falling edge.
- EITHer** triggering occurs on either edge.

Command Syntax	TRIGger:SEquence2:SLOPe:VOLTage<slope> TRIGger:ACQuire:SLOPe:VOLTage<slope>
Parameters	EITHer POSitive NEGative
*RST Value	EITHer
Examples	TRIG:SEQ2:SLOP:VOLT POS TRIG:ACQ:SLOP:VOLT EITH
Query Syntax	TRIGger:SEquence2:SLOPe:VOLTage? TRIGger:ACQuire:SLOPe:VOLTage?
Returned Parameters	<CRD>
Related Commands	TRIG:SEQ2:SLOP:CURR

TRIGger:SEquence2:SOURce TRIGger:ACQuire:SOURce

Agilent 66312A, 66332A Only

These commands select the trigger source for measurement triggers as follows:

BUS GPIB device, *TRG, or <GET> (Group Execute Trigger)
INTernal trigger is generated internally when the measured waveform crosses the trigger level with the selected slope.

Command Syntax	TRIGger:SEquence2:SOURce<source> TRIGger:ACQuire:SOURce<source>
Parameters	BUS INTernal
*RST Value	INTernal
Examples	TRIG:ACQ:SOUR BUS
Query Syntax	TRIGger:SEquence2:SOURce? TRIGger:ACQuire:SOURce?
Returned Parameters	<CRD>

TRIGger:SEquence1:DEFine TRIGger:SEquence2:DEFine

TRIGger:SEquence2:DEFine applies to Agilent 66312A, 66332A Only

These commands define the names that are aliased to trigger sequences 1 and 2. The command accepts only ACQuire for sequence 2 and TRANSient for sequence 1 as predefined names. The query allows the user to query the instrument names aliased to sequences 1 and 2.

Command Syntax	TRIGger:SEquence1:DEFine TRANSient TRIGger:SEquence2:DEFine ACQuire
Parameters	TRANSient, ACQuire
Examples	SEQ1:DEF ACQ SEQ2:DEF TRAN
Query Syntax	TRIGger:SEquence1:DEFine? TRIGger:SEquence2:DEFine?
Returned Parameters	<CRD>
Related Commands	TRIG:SEQ2:ACQ TRIG:SEQ1:TRAN

*TRG

This common command generates a trigger when the trigger subsystem has BUS selected as its source. The command has the same affect as the Group Execute Trigger (<GET>) command.

In RS-232 mode, this command emulates some of the functionality of the IEEE-488 Group Execute Trigger command.

Command Syntax	*TRG
Parameters	None
Related Commands	ABOR INIT TRIG[:IMM] <GET>

SCPI Conformance Information

SCPI Version

The Agilent Dynamic Measurement DC Source conforms to SCPI Version 1995.0.

SCPI Confirmed Commands

ABOR	SENS:SWE:POIN
CAL:DATA	SENS:SWE:TINT
CAL:STAT	STAT:OPER[:EVEN]?
DISP[:WIND][:STAT]	STAT:OPER:COND?
DISP[:WIND]:TEXT[:DATA]	STAT:OPER:ENAB
INIT[:IMM]:SEQ NAME	STAT:OPER:NTR
INIT:CONT:SEQ NAME	STAT:OPER:PTR
MEAS FETC:ARR:CURR[:DC]?	STAT:PRES
MEAS FETC:ARR:VOLT[:DC]?	STAT:QUES[:EVEN]?
MEAS FETC:SCAL:CURR[:DC]?	STAT:QUES:COND?
MEAS FETC:SCAL:CURR:HIGH?	STAT:QUES:ENAB
MEAS FETC:SCAL:CURR:LOW?	STAT:QUES:NTR
MEAS FETC:SCAL:CURR:MAX?	STAT:QUES:PTR
MEAS FETC:SCAL:CURR:MIN?	SYST:ERR?
MEAS FETC:SCAL:VOLT[:DC]?	SYST:LANG
MEAS FETC:SCAL:VOLT:HIGH?	SYST:VERS?
MEAS FETC:SCAL:VOLT:LOW?	TRIG:SEQ1 :TRAN[:IMM]
MEAS FETC:SCAL:VOLT:MAX?	TRIG:SEQ1 :TRAN:SOUR
MEAS FETC:SCAL:VOLT:MIN?	TRIG:SEQ2 ACQ[:IMM]
OUTP[:STAT]	TRIG:SEQ2 ACQ:SOUR
OUTP:PROT:CLE	TRIG:SEQ:DEF
OUTP:PROT:DEL	*CLS
[SOUR]:CURR[:LEV][:IMM][:AMPL]	*ESE*ESE?*ESR?
[SOUR]:CURR[:LEV]:TRIG:AMPL	*IDN?
[SOUR]:CURR:PROT:STAT	*OPC*OPC?*OPT?
[SOUR]:VOLT[:LEV][:IMM][:AMPL]	*PSC*PSC?
[SOUR]:VOLT[:LEV]:TRIG:AMPL	*RCL*RST
[SOUR]:VOLT:PROT	*SAV*SRE*STB?
SENS:CURR[:DC]:RANG[:UPP]	*TRG*TRG?
SENS:FUNC	*WAI
SENS:SWE:OFFS:POIN	

Non-SCPI Commands

CAL:CURR[:SOUR][:DC][:POS]	OUTP:DFI:SOUR
CAL:CURR[:SOUR][:DC]:NEG	OUTP:PON:STAT
CAL:MEAS[:DC]:LOWR	OUTP:REL[:STAT]
CAL:MEAS:AC	OUTP:REL:POL
CAL:LEV	OUTP:RI:MODE
CAL:PASS	SENS:CURR:DET
CAL:SAVE	[SOUR]:DIG:DATA[:VAL]
CAL:VOLT[:DC]	[SOUR]:DIG:FUNC
CAL:VOLT:PROT	TRIG:SEQ2 ACQ:COUN:CURR :VOLT
DISP[:WIND]:MODE	TRIG:SEQ2 ACQ:HYST:CURR :VOLT
MEAS FETC:SCAL:CURR:ACDC?	TRIG:SEQ2 ACQ:LEV:CURR :VOLT
MEAS FETC:SCAL:VOLT:ACDC?	TRIG:SEQ2 ACQ:SLOP:CURR :VOLT
OUTP:DFI[:STAT]	

Compatibility Language

Introduction

The Agilent power supplies covered by this manual are programmatically compatible with the HP/Agilent 6632A, 6633A, and 6634A dc power supplies. This means that by using COMPatibility language mode you can program these newer dc sources over the GPIB using COMPatibility commands.

To switch from SCPI commands to COMPatibility commands (and vice versa), use the SYST:LANG command, as documented in chapter 4. The language setting is saved in non-volatile memory.

Table B-2 summarizes the COMPatibility commands that program the supplies. You may need to refer to the HP/Agilent Series 6632, 6633A, and 6634A Operating Guide (p/n 5957-6360) for complete information on the COMPatibility commands.

The rest of this appendix discusses the COMPatibility language status system, and the COMPatibility language error codes.

Note: For complete information on the Compatibility programming language, order the HP/Agilent 6632A/6633A/6634A Operating manual, p/n 5957-6360.

Table B-1. COMPatibility Power-on Settings

Command	Setting	Command	Setting
DC	1 (ON)	POL	1 (normal)
DLY	8 ms (fast) 80 ms (normal)	PON	last stored value
DSP	1 (ON)	RELAY	1 (close)
ISET	0.04 A (6631B) 0.02 A (6632B) 0.008 A (6633B) 0.004 A (6634B)	RLYPON	1 (close)
OCP	OFF	SRQ	0
OUT	1 (ON)	UNMASK	0
OVSET	MAX	VSET	0 V

Table B-2. COMPatibility Commands

Compatibility Command	Description	Similar SCPI Command
ASTS?	This command reads the contents of the accumulated status register, which stores any bit condition entered in the status register since the accumulated status register was last read, regardless of whether the condition still exists. Data Representation: ZZZZD	STAT:OPER? STAT:QUES? *ESE?
CLR	This command initializes the dc source to the power-on state. It also resets the PON bit in the serial poll register. The command performs the same function as the Device Clear (DCL) interface message.	*RST
DC 0 1	Only applies to units with Relay Option 760. This command enables or disables the output without affecting the state of the output relays. Initial condition: DC 1	OUTP:STAT[:NOR] 0 1 OFF ON
DLY <n>	This command programs the delay time between the programming of an output change that produces a CV, CC, or an UNREG condition, and the recording of that condition by the status registers. This can be used to prevent false triggering of the OverCurrent Protection feature (OCP). Initial delay: 0.08s (Normal); 0.008s (Fast).	OUTP:PROT:DEL
DSP 0 1	This command enables or disables the dc source's front panel display. Initial condition: DSP 1	DISP 0 1 OFF ON
ERR?	This command determines the type of programming error detected by the dc source. A remote programming error sets the ERR bit in the status register, which can be enabled by UNMASK to request service.	SYST:ERR?
FAULT?	This command reads which bits have been set in the fault register. A bit is set in the fault register when the corresponding bit in the status register changes from inactive to active AND the corresponding bit in the mask register has been enabled. The fault register is reset only after it has been read. The decimal equivalent of the total bit weight of all enabled bits is returned. Data Representation: ZZZZD	STAT:OPER? STAT:QUES? *ESE
ID?	This command causes the dc source to report its model number and any options that affect the dc source's output. Data Representation: Agilent663XA	*IDN?
IOUT?	This command measures and returns the actual output current. Data Representation: SD.DDDD	MEAS:CURR?
ISSET <n>	This command programs the output current. See Table 4-3 for the programming range of this command. Initial condition: see Table B-1	CURR
OCP 0 1	This command enables or disables the dc source's overcurrent protection. If this function is enabled and the dc source goes into CC mode, the output of the dc source is disabled. Initial condition: OCP 0	CURR:PROT:STAT 0 1 OFF ON
OUT 0 1	This command enables or disables the dc source's output. The dc source will be able to implement commands even while the output is disabled. Initial condition: OUT 1	OUTP:STAT 0 1 OFF ON

Table B-2. COMPAtibility Commands (continued)

Compatibility Command	Description	Similar SCPI Command
OVSET <n>	This command programs the overvoltage protection. See Table 4-3 for the programming range of this command. Initial condition: MAX	VOLT:PROT
POL 0 1	Only applies to units with Option 760. This command sets the polarity of the output relays to either normal (1) or inverted (0). Initial condition: POL 1	OUTP:REL:POL 0 1
PON 0 1	This command enables (1) or disables (0) SRQ at power-on. Initial condition: last programmed value	PSC 0 1
RELAY 0 1	Only applies to units with Relay Option 760. This command opens (0) or closes (1) the output relays without affecting the programmed output state of the unit. Initial condition: RELAY 1	OUTP:REL 0 1
RLYPON 0 1	Only applies to units with Relay Option 760. This command opens (0) or closes (1) the output relays at power-on without affecting the programmed output state of the unit. Initial condition: RLYPON 1	RCL 0
ROM?	This command returns the ROM version of the dc source. Data Representation: AAA AAA	*IDN?
RST	This command resets the dc source if the output is disabled by the output protection circuits.	OUTP:PROT:CLE
SENS:CURRE:RANG <n>	This command sets the current measurement range of the dc source. See Table 4-3 for the programming range of this command. Initial condition: MAX	SENS:CURRE:RANG
SENS:SWE:POIN <n>	This command defines the number of data points in a measurement sweep. Initial condition: 32	SENS:SWE:POIN
SENS:SWE:TINT <n>	This command defines the time period between measurement samples. Initial condition: 15.6 μ s.	SENS:SWE:TINT
SRQ 0 1	These commands enable or disable the dc source's ability to request service from the controller for fault conditions. UNMASK defines which conditions are defined as faults. Initial condition: SRQ 0	*SRE
STS?	This command reads the contents of the status register, which maintains the present status of the dc source. Data Representation: ZZZZD	STAT:OPER:COND? STAT:QUES:COND? *ESE?
SYST:LANG	This command causes the alternate language to become active and to be stored in nonvolatile memory. In this case, the commands are equivalent. After being shut off, the dc source will resume in the last-selected language when power is restored. The parameter must be either COMP or SCPI.	SYST:LANG
TEST?	This command causes the dc source to run selftest and report any detected failures. Data Representation: ZZZZD	*TST?

B - Compatibility Language

Table B-2. COMPatibility Commands (continued)

Compatibility Command	Description	Similar SCPI Command
UNMASK xxx	These commands determine the conditions that will set bits in the fault register, allowing the operator to define the conditions that will be reported as fault. Fault conditions can be enabled by sending the decimal equivalent of the total bit weight of all conditions to be enabled.	STAT:OPER:ENAB STAT:QUES:ENAB *ESE
VOUT?	This command measures and returns the actual output voltage. Data Representation: SZZD.DD; (SZD.DDD for 6634B only)	MEAS:VOLT?
VSET <n>	This command programs the output voltage. See Table 4-3 for the programming range of this command. Initial condition: 0 V	VOLT

A = Alpha
D = Digit
S = Sign (blank for positive and – for negative)
Z = Digit with leading zeros output as spaces

Table B-3. COMPatibility Errors

Error	NumberError String [Description/Explanation/Examples]
ERR 0	No error
ERR 1	EEPROM save failed [Data write to non-volatile memory failed]
ERR 2	Second PON after power-on [More than one PON command received after power-on. Only one is allowed.]
ERR 4	RLYPON sent with no relay option present [A RLYPON command was sent with no relay option present.]
ERR 5	No relay option present [A relay option command was sent with no relay option present.]
ERR 8	Addressed to talk and nothing to say [The unit was addressed to talk without first receiving a query.]
ERR 10	Header expected [A non-alpha character was received when a header was expected.]
ERR 11	Unrecognized header [The string of alpha characters received was not a valid command.]
ERR 20	Number expected [A non-numeric character was received when a number was expected.]
ERR 21	Number Syntax [The numeric character received did not represent a proper number.]
ERR 22	Number out of internal range [The number received was too large or small to be represented in internal format.]
ERR 30	Comma [A comma was not received where one was expected.]
ERR 31	Terminator expected [A valid terminator was not received where one was expected.]
ERR 41	Parameter Out [The number received exceeded the limits for its associated command.]
ERR 42	Voltage Programming Error [The programmed value exceeded the valid voltage limits.]
ERR 43	Current Programming Error [The programmed value exceeded the valid current limits.]
ERR 44	Overvoltage Programming Error [The programmed value exceeded the valid overvoltage limits.]
ERR 45	Delay Programming Error [The programmed value exceeded the valid delay limits.]
ERR 46	Mask Programming Error [The programmed value exceeded the fault mask limits.]
ERR 51	EEPROM Checksum [EEPROM failed, or a new uncalibrated EEPROM was installed.]

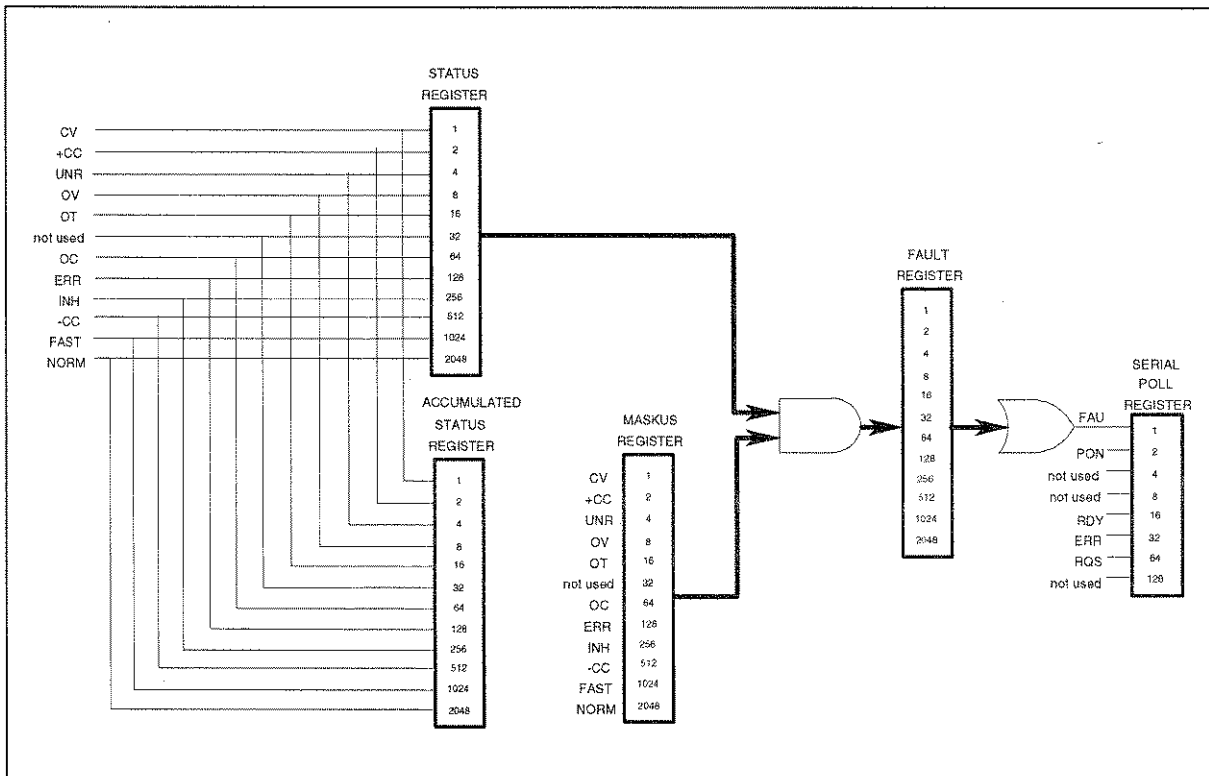

Figure B-1. Compatibility Status Model

Table B-4. Bit Assignment of Status, Astatus, Fault, & Mask Registers

Bit Position	11	10	9	8	7	6	5	4	3	2	1	0
Bit Name	NORM	FAST	-CC	INH	ERR	OC	not used	OT	OV	UNR	+CC	CV
Bit Weight	2048	1024	512	256	128	64	32	16	8	4	2	1

CV = The unit is operating in constant voltage mode.
 CC+ = The unit is operating in constant current mode.
 UNR = The output of the unit is unregulated.
 OV = The overvoltage protection circuit has tripped.
 OT = The over-temperature protection circuit has tripped.
 OC = The overcurrent protection circuit has tripped.
 ERR = A programming error has occurred. Use ERR? to clear.
 CC = The unit is operating in negative constant current mode.
 INH = The external remote inhibit signal has turned the output off.
 FAST = The output is in Fast operating mode. (Agilent 66332A, 6631B, 6632B, 6633B, 6634B only)
 NORM = The output is in Normal operating mode. (Agilent 66332A, 6631B, 6632B, 6633B, 6634B only)

Table B-5. Bit Configuration of Serial Poll Register

Bit Position	7	6	5	4	3	2	1	0
Bit Name	not used	RQS	ERR	RDY	not used	not used	PON	FAU
Bit Weight		64	32	16			2	1

RQS = The dc source has generated a service request. Use a serial poll to clear.
 ERR = Same as ERR bit in Status register. Use ERR? to clear.
 RDY = This bit cleared when unit busy processing commands. Set when processing complete.
 PON = A Power-on has occurred. Use CLR to clear.
 FAU = A bit has been set in the Fault register. Use FAULT? to clear.

Error Messages

Error Number List

This appendix gives the error numbers and descriptions that are returned by the dc source. Error numbers are returned in two ways:

- ◆ Error numbers are displayed on the front panel
- ◆ Error numbers and messages are read back with the SYSTem:ERRor? query. SYSTem:ERRor? returns the error number into a variable and returns two parameters: an NR1 and a string.

The following table lists the errors that are associated with SCPI syntax errors and interface problems. It also lists the device dependent errors. Information inside the brackets is not part of the standard error message, but is included for clarification.

When errors occur, the Standard Event Status register records them as follows:

Bit Set	Error Code	Error Type	Bit Set	Error Code	Error Type
5	-100 thru -199	Command	3	-300 thru -399 or 1 thru 32767	Device-dependent
4	200 thru -299	Execution	2	-400 thru -499	Query

Table C-1. Error Numbers

Error Number	Error String [Description/Explanation/Examples]
-100	Command error [generic]
-101	Invalid character
-102	Syntax error [unrecognized command or data type]
-103	Invalid separator
-104	Data type error [e.g., "numeric or string expected, got block data"]
-105	GET not allowed
-108	Parameter not allowed [too many parameters]
-109	Missing parameter [too few parameters]
-112	Program mnemonic too long [maximum 12 characters]
-113	Undefined header [operation not allowed for this device]
-121	Invalid character in number [includes "9" in octal data, etc.]
-123	Numeric overflow [exponent too large; exponent magnitude >32 k]
-124	Too many digits [number too long; more than 255 digits received]
-128	Numeric data not allowed
-131	Invalid suffix [unrecognized units, or units not appropriate]
-138	Suffix not allowed

C - Error Messages

Table C-1. Error Numbers (continued)

Error Number	Error String [Description/Explanation/Examples]
-141	Invalid character data [bad character, or unrecognized]
-144	Character data too long
-148	Character data not allowed
-150	String data error
-151	Invalid string data [e.g., END received before close quote]
-158	String data not allowed
-160	Block data error
-161	Invalid block data [e.g., END received before length satisfied]
-168	Block data not allowed
-170	Expression error
-171	Invalid expression
-178	Expression data not allowed
-200	Execution error [generic]
-222	Data out of range [e.g., too large for this device]
-223	Too much data [out of memory; block, string, or expression too long]
-224	Illegal parameter value [device-specific]
-225	Out of memory
-270	Macro error
-272	Macro execution error
-273	Illegal macro label
-276	Macro recursion error
-277	Macro redefinition not allowed
-310	System error
-350	Too many errors [errors beyond 9 lost due to queue overflow]
-400	Query error [generic]
-410	Query INTERRUPTED [query followed by DAB or GET before response complete]
-420	Query UNTERMINATED [addressed to talk, incomplete programming message received]
-430	Query DEADLOCKED [too many queries in command string]
-440	Query UNTERMINATED [after indefinite response]
0	No error
1	Non-volatile RAM RD0 section checksum failed
2	Non-volatile RAM CONFIG section checksum failed
3	Non-volatile RAM CAL section checksum failed
4	Non-volatile RAM STATE section checksum failed
5	Non-volatile RST section checksum failed
10	RAM selftest
11	VDAC/IDAC selftest 1
12	VDAC/IDAC selftest 2
13	VDAC/IDAC selftest 3
14	VDAC/IDAC selftest 4
15	OVDAC selftest
80	Digital I/O selftest error

Table C-1. Error Numbers (continued)

Error Number	Error String [Description/Explanation/Examples]
213	Ingrd receiver buffer overrun
216	RS-232 receiver framing error
217	RS-232 receiver parity error
218	RS-232 receiver overrun error
220	Front panel uart overrun
221	Front panel uart framing
222	Front panel uart parity
223	Front panel buffer overrun
224	Front panel timeout
401	CAL switch prevents calibration
402	CAL password is incorrect
403	CAL not enabled
404	Computed readback cal constants are incorrect
405	Computed programming cal constants are incorrect
406	Incorrect sequence of calibration commands
407	CV or CC status is incorrect for this command
408	Output mode switch must be in NORMAL position
601	Too many sweep points
602	Command only applies to RS-232 interface
603	CURRENT or VOLTAGE fetch incompatible with last acquisition
604	Measurement overrange

Example Programs

Introduction

The example programs in this section are intended to show how some of the same dc source functions can be programmed to each of the following GPIB interfaces:

1. HP Vectra PC controller with Agilent 82335A GPIB Interface Command Library
2. IBM PC controller with National Instruments GPIB-PCII Interface/Handler
3. Agilent controller with BASIC Language System

Assigning the GPIB Address in Programs

The dc source address cannot be set remotely. It must be set using the front panel Address key. Once the address is set, you can assign it inside programs. The following examples assume that the GPIB select code is 7, and the dc source is assigned to the variable PS.

```
1070 PS=706                !Agilent 82335A Interface
1070 ASSIGN @PS TO 706     !BASIC Interface
```

For systems using the National Instruments DOS driver, the address is specified in the software configuration program (IBCONFIG.EXE) and assigned a symbolic name. The address then is referenced only by this name within the application program (see the National Instruments GPIB documentation).

Types of DOS Drivers

The Agilent 82335A and National Instruments GPIB are two popular DOS drivers. Each is briefly described here. See the software documentation supplied with the driver for more details.

Agilent 82335A Driver

For GW-BASIC programming, the GPIB library is implemented as a series of subroutine calls. To access these subroutines, your application program must include the header file SETUP.BAS, which is part of the DOS driver software.

SETUP.BAS starts at program line 5 and can run up to line 999. Your application programs must begin at line 1000. SETUP.BAS has built-in error checking routines that provide a method to check for GPIB errors during program execution. You can use the error-trapping code in these routines or write your own code using the same variables as used by SETUP.BAS.

National Instruments GPIB Driver

Your program must include the National Instruments header file DECL.BAS. This contains the initialization code for the interface. Prior to running any applications programs, you must set up the interface with the configuration program (IBCONF.EXE).

D - Example Programs

Your application program will not include the dc source's symbolic name and GPIB address. These must be specified during configuration (when you run IBCONF.EXE). Note that the primary address range is from 0 to 30 but any secondary address must be specified in the address range of 96 to 126. The dc source expects a message termination on EOI or line feed, so set EOI w/last byte of Write. It is also recommended that you set Disable Auto Serial Polling.

All function calls return the status word IBSTA%, which contains a bit (ERR) that is set if the call results in an error. When ERR is set, an appropriate code is placed in variable IBERR%. Be sure to check IBSTA% after every function call. If it is not equal to zero, branch to an error handler that reads IBERR% to extract the specific error.

Error Handling

If there is no error-handling code in your program, undetected errors can cause unpredictable results. This includes "hanging up" the controller and forcing you to reset the system. Both of the above DOS drivers have routines for detecting program execution errors. Error detection should be used after every call to a subroutine.

BASIC Controllers

The BASIC Programming Language provides access to GPIB functions at the operating system level. This makes it unnecessary to have the header files required in front of DOS applications programs. Also, you do not have to be concerned about controller "hangups" as long as your program includes a timeout statement. Because the dc source can be programmed to generate SRQ on errors, your program can use an SRQ service routine for decoding detected errors. The detectable errors are listed in Appendix C.

Example 1. HP Vectra PC Controller Using Agilent 82335 Interface

```
5      '----- Merge SETUP.BAS here -----
1000  MAX.ELEMENTS=2 :ACTUAL.ELEMENTS=0 :MAX.LENGTH=80 :ACT.LENGTH=0
1005  DIM OUTPUTS(2) :CODES$=SPACE$(40)
1010  ISC=7 :PS=706
1015  '
1020  'Set up the DC Source Interface for DOS driver
1025  CALL IORESET (ISC)          'Reset the interface
1030  IF PCIB.ERR <> NOERR THEN ERROR PCIB.BASERR
1035  TIMEOUT=3
1040  CALL IOTIMEOUT (ISC, TIMEOUT)      'Set timeout to 3 seconds
1045  IF PCIB.ERR <> NOERR THEN ERROR PCIB.BASERR
1050  CALL IOCLEAR (ISC)              'Clear the interface
1055  IF PCIB.ERR <> NOERR THEN ERROR PCIB.BASERR
1060  CALL IOREMOTE (ISC)             'Set dc source to remote
mode
1065  IF PCIB.ERR <> NOERR THEN ERROR PCIB.BASERR
1070  '
1075  'Program dc source to CV mode with following voltage and current
1080  CODES$ = "VOLTAGE MAX;CURRENT MAX" :GOSUB 2000
```

Example Programs - D

```

1085 '
1090 'Query dc source outputs CURRENT?' :GOSUB 2000 :GOSUB 3000
1100 VOUT = OUTPUTS(1)
1105 IOUT = OUTPUTS(2)
1110 PRINT "The output levels are "VOUT" Volts and "IOUT" Amps"
1115 '
1120 'Program triggered current level to value insufficient to maintain
1125 'supply within its CV operating characteristic
1130 CODES$ = "CURR:TRIG MIN" :GOSUB 2000
1135 '
1140 'Set operation status mask to detect mode change from CV to CC
1145 CODES$ = "STAT:OPER:ENAB 1024;PTR 1024" :GOSUB 2000
1150 '
1155 'Enable Status Byte OPER summary bit
1160 CODES$ = "*SRE 128" :GOSUB 2000
1165 '
1170 'Arm trigger circuit and send trigger to dc source
1175 CODES$ = "INITIATE:SEQUENCE1;TRIGGER" :GOSUB 2000
1180 '
1185 'Wait for supply to respond to trigger
1190 FOR I= 1 to 100 :NEXT I
1195 '
1200 'Poll for interrupt caused by change to CC mode and print to
screen
1205 CALL IOS POLL (PS,RESPONSE)
1210 IF (RESPONSE AND 128) <> 128 THEN GOTO 1240 'No OPER event to
report
1215 CODES$ = "STATUS:OPER:EVEN?" :GOSUB 2000 'Query status oper
register
1220 CALL IOENTER (PS,OEVENT) 'Read back event bit
1225 IF PCIB.ERR <> NOERR THEN ERROR PCIB.BASERR
1230 IF (OEVENT AND 1024) = 1024 THEN PRINT "Supply switched to CC
mode."
1240 'Clear the status circuit
1245 CODES$ = "*CLS" :GOSUB 2000
1250 FOR I = 1 TO 100 :NEXT I 'Wait for supply to
clear
1255 '
1260 'Disable output and save present state in location 2
1265 CODES$ = "OUTPUT OFF;*SAV 2" :GOSUB 2000
1270 END
1275 '
2000 'Send command to dc source
2005 LENGTH = LEN(CODES$)
2010 CALL IOOUTPUTS (PS,CODES$,LENGTH) 'Send command to
interface
2015 IF PCIB.ERR <> NOERR THEN ERROR PCIB.BASERR 'SETUP.BAS error
trap
2020 RETURN
2025 '
3000 'Get data from dc source
3005 CALL IOENTERA (PS,OUTPUTS(1),MAX.ELEMENTS,ACTUAL.ELEMENTS)
3010 IF PCIB.ERR <> NOERR THEN ERROR PCIB.BASERR
3015 RETURN

```

D - Example Programs

Example 2. IBM Controller Using National Interface

```
990  '----- Merge DECL.BAS here -----
1000 'DC Source Variable = PS% ; Stand-Alone Address = 706
1005 CODES$=SPACE$(50):MODE$=SPACE$(5):OEVENT$=SPACE$(20)
1010 D$=SPACE$(60):OUTPUT$=SPACE$(40):BDNAME$="PS%"
1015 DIM OUTPUT(2)
1020 '
1025 'Set up dc source interface for DOS driver
1030 CALL IBFIND(BDNAME$,PS%)
1035 IF PS%
1040 CALL IBCLR(PS%)
1045 '
1050 'Program dc source to CV mode with following voltage and current
1055 CODES$ = "VOLTAGE MAX;CURRENT MAX" :GOSUB 2000
1060 '
1065 'Query dc source outputs and print to screen
1070 CODES$ = "MEASURE:VOLTAGE?;CURRENT?" :GOSUB 2000 :GOSUB 3000
1075 VOUT = OUTPUT(1)
1080 IOUT = OUTPUT(2)
1085 PRINT"The programmed levels are "VOUT" Volts and "IOUT" Amps"
1090 '
1095 'Program triggered current level to value insufficient to maintain
1100 'supply within its CV operating characteristic
1105 CODES$ = "CURR:TRIG MIN" :GOSUB 2000
1110 '
1115 'Set operation status mask to detect mode change from CV to CC
1120 CODES$ = "STAT:OPER:ENAB 1024;PTR 1024" :GOSUB 2000
1125 '
1130 'Enable Status Byte OPER summary bit
1135 CODES$ = "*SRE 128" :GOSUB 2000
1140 '
1145 'Arm trigger circuit and send trigger to dc source
1150 CODES$ = "INITIATE:SEQUENCE1;TRIGGER" :GOSUB 2000
1160 'Wait for supply to respond to trigger
1165 FOR I= 1 to 100 :NEXT I
1170 '
1175 'Poll for interrupt caused by change to CC mode and print to screen
1180 SPOL%=0
1185 CALL IBRSP(PS%,SPOL%)
1190 IF (SPOL% AND 128) = 128 THEN POLL = 1 'Set interrupt flag on
OPER bit
1195 IF POLL <> 1 THEN GOTO 1230 'No interrupt to
service
1200 CODES$ = "STAT:OPER:EVEN?" :GOSUB 2000 'Query status oper
register
1205 CALL IBRD(PS%,OEVENT$) 'Read back event bit
1210 IF IBSTA%
1215 OEVENT=VAL(OEVENT$)
1220 IF (OEVENT AND 1024) = 1024 THEN PRINT "Supply switched to CC mode."
```

Example Programs - D

```

1225 '
1230 'Clear status circuit
1235 CODES$="*CLS" :GOSUB 2000
1240 FOR I=1 TO 50 :NEXT I 'Wait for supply to clear
1245 '
1250 'Disable output and save present state to location 2
1255 CODES$ = "OUTPUT OFF;*SAV 2" :GOSUB 2000
1260 END
1265 '
2000 'Send command to dc source
2005 CALL IBWRT(PS%,CODES$)
2010 IF IBSTAT%
2015 RETURN
1250 'Disable output and save present state to location 2
1255 CODES$ = "OUTPUT OFF;*SAV 2" :GOSUB 2000
1260 END
1265 '
2000 'Send command to dc source
2005 CALL IBWRT(PS%,CODES$)
2010 IF IBSTAT%
2015 RETURN
2020 '
2100 'Error detection routine
2105 PRINT "GPIO error. IBSTAT% = HEX$(IBSTAT%)
2110 PRINT " IBERR% = ";IBERR%" in line ";ERL
2115 STOP
2120 '
3000 'Get data from dc source
3005 CALL IBRD(PS%,OUTPUT$)
3010 IF IBSTA%
3015 I=1 'Parse data string
3020 X=1
3025 C=INSTR(I,OUTPUT$,";")
3030 WHILE C <> 0
3035 D$=MID$(OUTPUT$,I,C-I)
3040 OUTPUT(X)=VAL(D$) 'Get values
3045 I=C+1
3050 C=INSTR(I,OUTPUT$,";")
3055 X=X+1
3060 WEND
3065 D$=RIGHT$(OUTPUT$,LEN(OUTPUT$)-(I-1))
3070 OUTPUT(X)=VAL(D$)
3075 OUTPUT$=SPACE$(40) 'Clear string
3080 RETURN

```

D - Example Programs

Example 3. Controller Using BASIC

```
1000 !Dc source at stand-alone address = 706
1010 OPTION BASE 1
1020 DIM Response$(80)
1030 ASSIGN @Ps TO 706
1040 CLEAR SCREEN
1050 !
1060 PRINT "Disconnect any load from output terminals and press
CONTINUE..."
1070 PAUSE
1080 !
1090 !Program dc source with following voltage level and current limit
1100 OUTPUT @Ps;"VOLT MAX"
1110 OUTPUT @Ps;"CURR MAX"
1120 OUTPUT @Ps;"OUTP ON"
1130 !
1140 !Query dc source outputs and print to screen
1150 OUTPUT @Ps;"MEAS:VOLT?;CURR?"!Query output levels
1160 ENTER @Ps;Vout,Iout
1170 PRINT "The output levels are ";Vout;" Volts and ";Iout;" Amps"
1180 !
1190 !Program current triggered level to a value insufficient to
maintain
1200 !supply within its CV operating characteristic
1210 OUTPUT @Ps;"CURR:TRIG MIN"
1220 !
1230 !Set operation status mask to detect mode change from CV to CC
1240 OUTPUT @Ps;"STAT:OPER:ENAB 1024;PTR 1024"
1250 !
1260 !Enable Status Byte OPER summary bit
1270 OUTPUT @Ps;"*SRE 128"
1280 !
1290 !Arm trigger circuit and send trigger to dc source
1300 OUTPUT @Ps;"INIT:NAME TRAN"
1310 OUTPUT @Ps;"TRIGGER"
1320 !Poll for interrupt caused by change to CC mode and print to screen
1330 PRINT "Connect 1K ohm load and hit CONTINUE..."
1340 PAUSE
1350 Response=SPOLL(@Ps)
1360 IF NOT BIT(Response,7) THEN !No OPER event to report
1370 PRINT "Supply not in CC mode!!!"
1380 GOTO 1320
1390 END IF
1400 OUTPUT @Ps;"STAT:OPER:EVEN?"!Query status operation register
1410 ENTER @Ps;Oevent!Read back event bit
1420 IF BIT(Oevent,10) THEN PRINT "Supply switched to CC mode."
1430 !
1440 !Clear status
1450 OUTPUT @Ps;"*CLS"
1460 !
1470 !Disable output and save present state in location 2
1480 OUTPUT @Ps;"OUTPUT OFF;*SAV 2"
1490 PRINT "Program terminated."
1500 END
```

INDEX

—A—

AARD, 16
ABORT, 73
ACDC, 52

—B—

bus, 79

—C—

calibration commands, 44
CAL CURR, 44
CAL CURR MEAS AC, 44
CAL CURR NEG, 44
CAL DATA, 45
CAL LEV, 45
CAL PASS, 45
CAL SAVE, 45
CAL STAT, 46
CAL VOLT, 46
CAL VOLT PROT, 46
calibration commands:CAL CURR MEAS LOWR ",
44
character strings, 16
combine commands
common commands, 14
from different subsystems, 14
root specifier, 14
command completion, 17
common command syntax, 43
common commands, 61, 68
*CLS, 64
*ESE, 65
*ESR?, 65
*IDN?, 70
*OPC, 65
*OPT?, 71
*PSC, 66
*RCL, 71
*RST, 71
*SAV, 72
*SRE, 66
*STB?, 67
*TRG, 79
*TST, 72
*WAI, 67
compatibility
commands, 84
errors, 86
language, 83
power-on settings, 83
status model, 87
conventions used in this guide, 12
CRD, 16
current, 20

maximum, 20
measurement range, 24
measurements, 23
current measurement detector, 28, 52
current measurement range, 52

—D—

DC, 52
dc measurements, 23
determining cause of interrupt, 35
device clear, 17
DFI, 36
DFI programming example, 37
digital I/O port, 37
discrete fault indicator, 36
display commands, 68
DISP, 68
DISP MODE, 68
DISP TEXT, 68
DOS driver types, 93
DTR-DSR, 11

—E—

either, 78
enabling the output, 19
error handling, 94
error numbers, 89
example
controller using HP BASIC, 98
DFI programming, 37
HP Vectra with HP 82335 interface, 94
IBM controller using National interface, 96
programs, 93
pulse measurement, 11, 30

—F—

fault indicator
discrete, 36
remote inhibit, 36
fetch commands, 23, 47
FLT, 36

—G—

general information, 7
generating measurement triggers, 26
generating triggers, 22
GP-IB
command library for MS DOS, 8
controller programming, 8
IEEE Std for standard codes, 8
IEEE Std for standard digital interface, 8
references, 8

Index

—H—

hanning, 54
header, 15
 long form, 15
 short form, 15
history, 2
HP 8235A driver, 93
HP BASIC controllers, 94
HP-IB
 address, 10
 capabilities of the dc source, 10
 triggers, 26

—I—

INH, 36
initialization, 19
initiate commands, 73
 INIT CONT NAME, 73
 INIT CONT SEQ, 73
 INIT NAME, 73
 INIT SEQ, 73
initiating measurement trigger system, 25
initiating output trigger system, 22
internal, 79
internal triggers, 26
internally triggered measurements, 25

—L—

language, 83
language dictionary, 39
latching, 57
live, 57

—M—

making measurements, 23
MAV bit, 35
maximum measurements, 24
measure commands, 23, 47
 MEAS ARRy CURR?, 47
 MEAS ARRy VOLT?, 47
 MEAS CURR ACDC?, 48
 MEAS CURR HIGH?, 48
 MEAS CURR LOW?, 49
 MEAS CURR MAX?, 49
 MEAS CURR MIN?, 49
 MEAS CURR?, 48
 MEAS VOLT ACDC?, 50
 MEAS VOLT HIGH?, 50
 MEAS VOLT LOW?, 51
 MEAS VOLT MAX?, 51
 MEAS VOLT MIN?, 51
 MEAS VOLT?, 50
measurement trigger system model, 25
measuring output pulses, 28
message terminator, 15
 end or identify, 15

 newline, 15
message unit
 separator, 15
minimum measurements, 24
monitoring both phases of status transition, 36
moving among subsystems, 14
MSS bit, 35
multiple measurements, 29

—N—

National Instruments GPIB driver, 93
negative, 78
numerical data formats, 16

—O—

OCP, 20
operation status group, 33
optional header
 example, 14
output commands, 55
 OUTP, 55
 OUTP DFI, 55
 OUTP DFI SOUR, 55
 OUTP PON STAT, 56
 OUTP PROT CLE, 56
 OUTP PROT DEL, 56
 OUTP REL, 57
 OUTP REL POL, 57
 OUTP RI MODE, 57
output queue, 35
output trigger system model, 21
overcurrent protection, 20

—P—

PON (power on) bit, 34
positive, 78
post-event triggering, 30
power-on conditions, 32
power-on initialization, 19
pre-event triggering, 30
print date, 2
program examples, 93
programming parameters, 43
programming status registers, 32
programming the output, 19
pulse measurement example, 11, 30
pulse measurement queries, 28
pulse waveforms, 28

—Q—

queries, 14
query
 indicator, 15
questionable status group, 34

—R—

rectangular, 54
 remote inhibit, 36
 returning voltage or current data, 24
 RI, 36
 rms measurements, 24
 root specifier, 15
 RQS bit, 35
 RS-232
 capabilities of the dc source, 10
 data format, 10, 12
 data terminator, 16
 flow control, 11
 RTS-CTS, 11

—S—

safety guidelines, 2
 SCPI
 command completion, 17
 command syntax, 39
 command tree, 13
 common commands, 13
 conformance, 81
 data format, 16
 device clear, 17
 header path, 13
 message structure, 14
 message types, 14
 message unit, 15
 multiple commands, 13
 non-conformance, 81
 program message, 14
 references, 8
 response message, 14
 subsystem commands, 13, 39
 triggering nomenclature, 21, 25
 selecting measurement trigger source, 26
 sense commands, 47
 SENS CURR DET, 52
 SENS CURR RANG, 52
 SENS FUNC, 53
 SENS SWE OFFS POIN, 53
 SENS SWE POIN, 53
 SENS SWE TINT, 53
 SENS WIND, 54
 servicing operation status, 35
 servicing questionable status events, 35
 setting output trigger system, 21
 source commands, 55
 [SOUR] CURR, 58
 [SOUR] CURR PROT STAT, 58
 [SOUR] CURR TRIG, 58
 [SOUR] DIG DATA, 59
 [SOUR] DIG FUNC, 59
 [SOUR] VOLT, 59
 [SOUR] VOLT ALC BAND?, 60
 [SOUR] VOLT PROT, 60
 [SOUR] VOLT TRIG, 60
 SRD, 16

standard event status group, 34
 status bit configurations, 33
 status byte register, 34
 status commands, 61
 STAT OPER COND?, 61
 STAT OPER ENAB, 62
 STAT OPER NTR, 62
 STAT OPER PTR, 62
 STAT OPER?, 61
 STAT PRES, 61
 STAT QUES COND?, 63
 STAT QUES ENAB, 63
 STAT QUES NTR, 64
 STAT QUES PTR, 64
 STAT QUES?, 63
 status model, 32
 subsystem commands syntax, 40
 suffixes, 16
 system commands, 68
 SYST ERR?, 69
 SYST LANG, 69, 83
 SYST LOC, 70
 SYST REM, 70
 SYST RWL, 70
 SYST VERS?, 69
 system errors, 89

—T—

trigger commands, 73
 TRIG, 74
 TRIG ACQ, 74
 TRIG ACQ COUN CURR, 75
 TRIG ACQ COUN VOLT, 75
 TRIG ACQ HYST CURR, 76
 TRIG ACQ HYST VOLT, 76
 TRIG ACQ LEV CURR, 77
 TRIG ACQ LEV VOLT, 77
 TRIG ACQ SLOP CURR, 78
 TRIG ACQ SLOP VOLT, 78
 TRIG ACQ SOUR, 79
 TRIG SEQ1 DEF, 79
 TRIG SEQ2, 74
 TRIG SEQ2 COUN CURR, 75
 TRIG SEQ2 COUN VOLT, 75
 TRIG SEQ2 DEF, 79
 TRIG SEQ2 HYST CURR, 76
 TRIG SEQ2 HYST VOLT, 76
 TRIG SEQ2 LEV CURR, 77
 TRIG SEQ2 LEV VOLT, 77
 TRIG SEQ2 SLOP CURR, 78
 TRIG SEQ2 SLOP VOLT, 78
 TRIG SEQ2 SOUR, 79
 TRIG SOUR, 74
 triggering output changes, 21
 triggers
 continuous, 22
 single, 22
 types of SCPI commands, 13

Index

—V—

varying voltage or current sampling, 29
voltage, 20
 maximum, 20
 measurements, 23

—W—

waiting for measurement results, 27

—X—

XON-XOFF, 11

Manual Updates

The following updates have been made to this manual since the December 1998 printing indicated on the Printing History page.

11/9/99

Information about installing VXI*plug&play* Power Products Instrument Drivers has been included in the beginning of chapter 2.

1/4/00

All references to HP have been changed to Agilent.

All references to HP-IB have been changed to GPIB.

USER'S GUIDE
Dynamic Measurement DC Source
Agilent Model 66312A
System DC Power Supply
Agilent 6611C, 6612C, 6613C and 6614C

For instruments with Serial Numbers:

Agilent 66312A: US36310891 and up

Agilent 6611C: US37450101 and up

Agilent 6612C: US37460101 and up

Agilent 6613C: US37460101 and up

Agilent 6614C: US37460101 and up



Agilent Technologies
Innovating the HP Way

Agilent Part No. 5962-8194

Microfiche No. 5962-8195

Printed in USA: January 2000

Warranty Information

CERTIFICATION

Agilent Technologies certifies that this product met its published specifications at time of shipment from the factory. Agilent Technologies further certifies that its calibration measurements are traceable to the United States National Bureau of Standards, to the extent allowed by the Bureau's calibration facility, and to the calibration facilities of other International Standards Organization members.

WARRANTY

This Agilent Technologies hardware product is warranted against defects in material and workmanship for a period of three years from date of delivery. Agilent software and firmware products, which are designated by Agilent for use with a hardware product and when properly installed on that hardware product, are warranted not to fail to execute their programming instructions due to defects in material and workmanship for a period of 90 days from date of delivery. During the warranty period Agilent Technologies will, at its option, either repair or replace products which prove to be defective. Agilent does not warrant that the operation for the software firmware, or hardware shall be uninterrupted or error free.

For warranty service, with the exception of warranty options, this product must be returned to a service facility designated by Agilent. Customer shall prepay shipping charges by (and shall pay all duty and taxes) for products returned to Agilent for warranty service. Except for products returned to Customer from another country, Agilent shall pay for return of products to Customer.

Warranty services outside the country of initial purchase are included in Agilent's product price, only if Customer pays Agilent international prices (defined as destination local currency price, or U.S. or Geneva Export price).

If Agilent is unable, within a reasonable time to repair or replace any product to condition as warranted, the Customer shall be entitled to a refund of the purchase price upon return of the product to Agilent.

LIMITATION OF WARRANTY

The foregoing warranty shall not apply to defects resulting from improper or inadequate maintenance by the Customer, Customer-supplied software or interfacing, unauthorized modification or misuse, operation outside of the environmental specifications for the product, or improper site preparation and maintenance. NO OTHER WARRANTY IS EXPRESSED OR IMPLIED. AGILENT SPECIFICALLY DISCLAIMS THE IMPLIED WARRANTIES OF MERCHANTABILITY AND FITNESS FOR A PARTICULAR PURPOSE.

EXCLUSIVE REMEDIES

THE REMEDIES PROVIDED HEREIN ARE THE CUSTOMER'S SOLE AND EXCLUSIVE REMEDIES. AGILENT SHALL NOT BE LIABLE FOR ANY DIRECT, INDIRECT, SPECIAL, INCIDENTAL, OR CONSEQUENTIAL DAMAGES, WHETHER BASED ON CONTRACT, TORT, OR ANY OTHER LEGAL THEORY.

ASSISTANCE

The above statements apply only to the standard product warranty. Warranty options, extended support contacts, product maintenance agreements and customer assistance agreements are also available. Contact your nearest Agilent Technologies Sales and Service office for further information on Agilent's full line of Support Programs.

Safety Summary

The following general safety precautions must be observed during all phases of operation of this instrument. Failure to comply with these precautions or with specific warnings elsewhere in this manual violates safety standards of design, manufacture, and intended use of the instrument. Agilent Technologies assumes no liability for the customer's failure to comply with these requirements.

GENERAL

This product is a Safety Class 1 instrument (provided with a protective earth terminal). The protective features of this product may be impaired if it is used in a manner not specified in the operation instructions.

Any LEDs used in this product are Class 1 LEDs as per IEC 825-1.

ENVIRONMENTAL CONDITIONS

This instrument is intended for indoor use in an installation category II, pollution degree 2 environment. It is designed to operate at a maximum relative humidity of 95% and at altitudes of up to 2000 meters. Refer to the specifications tables for the ac mains voltage requirements and ambient operating temperature range.

BEFORE APPLYING POWER

Verify that the product is set to match the available line voltage, the correct fuse is installed, and all safety precautions are taken. Note the instrument's external markings described under "Safety Symbols".

GROUND THE INSTRUMENT

To minimize shock hazard, the instrument chassis and cover must be connected to an electrical ground. The instrument must be connected to the ac power mains through a grounded power cable, with the ground wire firmly connected to an electrical ground (safety ground) at the power outlet. Any interruption of the protective (grounding) conductor or disconnection of the protective earth terminal will cause a potential shock hazard that could result in personal injury.

ATTENTION: Un circuit de terre continu est essentiel en vue du fonctionnement sécuritaire de l'appareil. Ne jamais mettre l'appareil en marche lorsque le conducteur de mise ... la terre est d,branch,.

FUSES

Only fuses with the required rated current, voltage, and specified type (normal blow, time delay, etc.) should be used. Do not use repaired fuses or short-circuited fuseholders. To do so could cause a shock or fire hazard.

DO NOT OPERATE IN AN EXPLOSIVE ATMOSPHERE

Do not operate the instrument in the presence of flammable gases or fumes.

DO NOT REMOVE THE INSTRUMENT COVER

Operating personnel must not remove instrument covers. Component replacement and internal adjustments must be made only by qualified service personnel.

Instruments that appear damaged or defective should be made inoperative and secured against unintended operation until they can be repaired by qualified service personnel.

SAFETY SYMBOLS



Direct current



Alternating current



Both direct and alternating current



Three-phase alternating current



Earth (ground) terminal



Protective earth (ground) terminal



Frame or chassis terminal



Terminal is at earth potential. Used for measurement and control circuits designed to be operated with one terminal at earth potential.



Terminal for Neutral conductor on permanently installed equipment



Terminal for Line conductor on permanently installed equipment



On (supply)



Off (supply)



Standby (supply). Units with this symbol are not completely disconnected from ac mains when this switch is off. To completely disconnect the unit from ac mains, either disconnect the power cord or have a qualified electrician install an external switch.



In position of a bi-stable push control



Out position of a bi-stable push control



Caution, risk of electric shock



Caution, hot surface



Caution (refer to accompanying documents)

WARNING

The WARNING sign denotes a hazard. It calls attention to a procedure, practice, or the like, which, if not correctly performed or adhered to, could result in personal injury. Do not proceed beyond a WARNING sign until the indicated conditions are fully understood and met.

Caution

The CAUTION sign denotes a hazard. It calls attention to an operating procedure, or the like, which, if not correctly performed or adhered to, could result in damage to or destruction of part or all of the product. Do not proceed beyond a CAUTION sign until the indicated conditions are fully understood and met.

Declaration Page

DECLARATION OF CONFORMITY according to ISO/IEC Guide 22 and EN 45014

Manufacturer's Name: Agilent Technologies

Manufacturer's Address: 140 Green Pond Road
Rockaway, New Jersey 07866
U.S.A.

declares that the Product

Product Name: a) Dynamic Measurement DC Source
b) System DC Power Supply

Model Number: a) Agilent 66312A, 66312B
b) Agilent 6612B, 6611C, 6612C, 6613C, 6614C

conforms to the following Product Specifications:

Safety: IEC 1010-1:1990+A1(1992) / EN 61010-1:1993

EMC: CISPR 11:1990 / EN 55011:1991 - Group 1 Class B
IEC 801-2:1991 / EN 50082-1:1992 - 4 kV CD, 8 kV AD
IEC 801-3:1984 / EN 50082-1:1992 - 3 V / m
IEC 801-4:1988 / EN 50082-1:1992 - 0.5 kV Signal Lines
1 kV Power Lines

Supplementary Information:

The product herewith complies with the requirements of the Low Voltage Directive 73/23/EEC and the EMC Directive 89/336/EEC and carries the CE-marking accordingly.

New Jersey
Location

January 1997
Date



Bruce Krueger / Quality Manager

European Contact: Your local Agilent Technologies Sales and Service Office or Agilent Technologies GmbH,
Department TRE, Herrenberger Strasse 130, D-71034 Boeblingen (FAX:+49-7031-14-3143)

Acoustic Noise Information

Herstellerbescheinigung

Diese Information steht im Zusammenhang mit den Anforderungen der Maschinenlärminformationsverordnung vom 18 Januar 1991.

- * Schalldruckpegel $L_p < 70$ dB(A)
- * Am Arbeitsplatz
- * Normaler Betrieb
- * Nach EN 27779 (Typprüfung).

Manufacturer's Declaration

This statement is provided to comply with the requirements of the German Sound Emission Directive, from 18 January 1991.

- * Sound Pressure $L_p < 70$ dB(A)
- * At Operator Position
- * Normal Operation
- * According to EN 27779 (Type Test).

Printing History

The edition and current revision of this manual are indicated below. Reprints of this manual containing minor corrections and updates may have the same printing date. Revised editions are identified by a new printing date. A revised edition incorporates all new or corrected material since the previous printing date.

Changes to the manual occurring between revisions are covered by change sheets shipped with the manual. In some cases, the manual change applies only to specific instruments. Instructions provided on the change sheet will indicate if a particular change applies only to certain instruments.

This document contains proprietary information protected by copyright. All rights are reserved. No part of this document may be photocopied, reproduced, or translated into another language without the prior consent of Agilent Technologies. The information contained in this document is subject to change without notice.

© Copyright 1997 Agilent Technologies

Edition 1 _____November, 1997
Update 1 _____July, 1999
Update 2 _____January, 2000

Table of Contents

Warranty Information	2
Safety Summary	3
Declaration Page	5
Acoustic Noise Information	6
Printing History	6
Table of Contents	7
1 - QUICK REFERENCE	9
Agilent 66312A Dynamic Measurement DC Source and Agilent 6611C/6612C/6613C/6614C System DC Power Supply	9
The Front Panel - At a Glance	10
Front Panel Number Entry	11
Front Panel Annunciators	12
Immediate Action Keys	12
Front Panel Menus - At a Glance	13
SCPI Programming Commands - At a Glance	14
The Rear Panel - At a Glance	15
2 - GENERAL INFORMATION	17
Document Orientation	17
Safety Considerations	18
Options and Accessories	18
Description	19
Capabilities	19
Front Panel Controls	19
Remote Programming	19
Output Characteristic	20
3 - INSTALLATION	21
Inspection	21
Damage	21
Packaging Material	21
Items Supplied	21
Cleaning	21
Location	22
Bench Operation	22
Rack Mounting	22
Input Connections	23
Connect the Power Cord	23
Output Connections	23
Wire Considerations	23
Current Ratings	23
Voltage Drops	24
Multiple Load Connections	24
Remote Sense Connections	25
Sense Leads	25
Stability	26
OVP Considerations	26
INH/FLT Connections	26
Controller Connections	28
GPIB Interface	28
RS-232 Interface	29

4 - TURN-ON CHECKOUT	31
Introduction	31
Using the Keypad	31
Checkout Procedure	32
In Case of Trouble	34
Error Messages	34
Line Fuse	34
5 - FRONT PANEL OPERATION	35
Introduction	35
Front Panel Description	35
System Keys	37
Function Keys	38
Immediate Action Keys	38
Scrolling Keys	38
Metering Keys	39
Output Control Keys	40
Entry Keys	41
Examples of Front Panel Programming	42
1 - Setting the Output Voltage and Current	42
2 - Querying and Clearing Output Protection	43
3 - Making Front Panel Measurements	43
4 - Programming the Digital Output Port	45
5 - Programming the Output Relay (option 760 only)	46
6 - Setting the GPIB Address and RS-232 Parameters	46
7 - Saving and Recalling Operating States	47
A - SPECIFICATIONS	49
Specifications	49
Supplemental Characteristics	50
B - VERIFICATION AND CALIBRATION	53
Introduction	53
Equipment Required	53
Test Setup	53
Performing the Verification Tests	54
Turn-On Checkout	55
Voltage Programming and Measurement Accuracy	55
Current Programming and Measurement Accuracy	55
Performing the Calibration Procedure	59
Front Panel Calibration Menu	59
Front Panel Calibration	60
Calibration Error Messages	62
Changing the Calibration Password	62
Calibration Over the GPIB	63
C - ERROR MESSAGES	65
Error Number List	65
D - LINE VOLTAGE CONVERSION	69
Open the Unit	69
Configure the Power Transformer	69
Install the Correct Line Fuse	70
Close the Unit	70
INDEX	71

Quick Reference

Agilent 66312A Dynamic Measurement DC Source and Agilent 6611C/6612C/6613C/6614C System DC Power Supply

The Agilent 66312A is a 40 Watt, high performance dc power supply that provides dynamic measurement and analysis of voltage and current waveforms. It is designed to simplify the testing of digital cellular and mobile phones. For example, data acquired using its dynamic measurement capability can be used in determining the battery operating time of digital wireless communications products.

The Agilent 6611C, 6612C, 6613C and 6614C are 40 and 50 Watt, high performance dc power supplies with output current measurement capability in the microampere range. They are well suited for testing portable battery-powered products.

Additionally, the combination of bench-top and system features in these dc sources provide versatile solutions for your design and test requirements.

Convenient bench-top features

- ◆ Up to 50 Watts output power
- ◆ Easy to use knob for voltage and current settings
- ◆ Highly visible vacuum-fluorescent front panel display
- ◆ Excellent load and line regulation; low ripple and noise
- ◆ Measurement capability down to microampere levels
- ◆ Current sinking up to 30% of the rated current
- ◆ Instrument state storage
- ◆ Portable case



Flexible system features

- ◆ GPIB (IEEE-488) and RS-232 interfaces are standard
- ◆ SCPI (Standard Commands for Programmable Instruments) compatibility
- ◆ Triggered acquisition of digitized output current and voltage waveforms (Agilent 66312A only)
- ◆ I/O setup easily done from the front panel

The Front Panel - At a Glance

① 14-character display shows output measurements and programmed values.

② Annunciators indicate operating modes and status conditions.

③ Rotary control sets voltage, current, and menu parameters. Use  and  to set the resolution; then adjust the value with the knob.

④ Front panel output connectors.

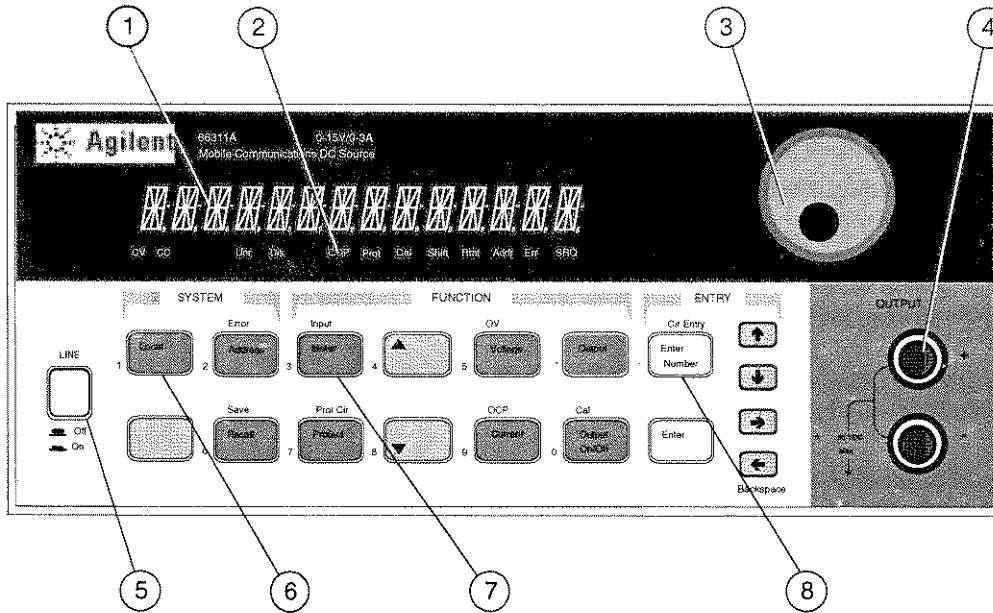



⑤ Turns the dc source on and off.





⑥ System keys:

- ◆ return to Local mode
- ◆ set the GPIB address
- ◆ set the RS-232 interface
- ◆ display SCPI error codes
- ◆ save and recall instrument states.

⑦ Function keys:

- ◆ enable/disable output
- ◆ select metering functions
- ◆ program voltage and current
- ◆ set and clear protection functions
- ◆  and  scroll through the front panel menu commands.

⑧ Entry keys:

- ◆ enter values
- ◆ increment or decrement values
- ◆  and  select front panel menu parameters.
- ◆  and  select a digit in the numeric entry field.

Front Panel Number Entry

Enter numbers from the front panel using one of the following methods:

Use the arrow keys and knob to change voltage or current settings



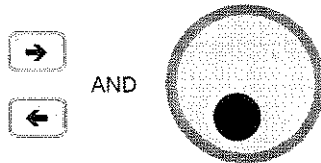

NOTE The output must be ON to see the displayed values change in Meter mode.

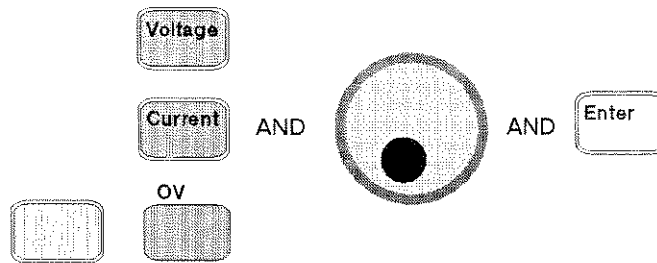

Use the Function keys and knob to change the displayed settings



Use the arrow keys to edit individual digits in the displayed setting

-  Increments the flashing digit
-  Decrements the flashing digit
-  Moves the flashing digit to the right
-  Moves the flashing digit to the left
-  Enters the value when editing is complete

Use the Function keys and Entry keys to enter a new value

NOTE If you make a mistake, use the Backspace key to delete the number, or press the Meter key to return to meter mode.

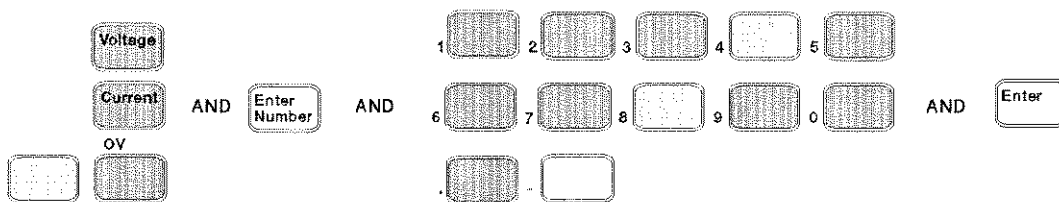

Front Panel Annunciators



CV CC Unr Dis OCP Prot Cal Shift Rmt Addr Err SRQ



CV	The output is operating in constant voltage mode.
CC	The output is operating in constant current mode.
Unr	The output is unregulated.
Dis	The output is OFF. Press the Output On/Off key to turn the output on.
OCP	The over-current protection state is ON. Press the OCP key to turn over-current protection off.
Prot	Indicates that the output has been disabled by one of the protection features. Press the Prot Clear key to clear the protection condition.
Cal	Calibration mode is ON. Scroll to the Cal Off command and press the Enter key to exit the calibration mode.
Shift	The Shift key has been pressed.
Rmt	The selected Remote programming interface (either GPIB or RS-232) is active. Press the Local key to return the unit to front panel control.
Addr	The interface is addressed to talk or listen.
Err	There is an error in the SCPI error queue. Press the Error key to view the error code.
SRQ	The interface is requesting service.

Immediate Action Keys

Output On/Off	A toggle switch that turns the output of the dc source on or off.
Local	Activates front panel control when the unit is in remote mode (unless a Lockout command is in effect).
Shift Prot Clr	Resets the protection circuit and allows the unit to return to its last programmed state.
Shift OCP	A toggle switch that enables or disables overcurrent protection.

Front Panel Menus - At a Glance

Address		<i>ADDRESS 7</i>	Sets the GPIB Address
	▼	<i>INTF GPIB</i>	Selects an interface (GPIB or RS232)
	▼	<i>BAUDRATE 300</i>	Selects baud rate (300, 600, 1200, 2400, 4800, 9600)
	▼	<i>PARITY NONE</i>	Selects message parity (NONE, EVEN, ODD, MARK, SPACE)
	▼	<i>FLOW NONE</i>	Selects flow control (XON-XOFF, RTS-CTS, DTR-DSR, NONE)
	▼	<i>LANG SCPI</i>	Selects language (SCPI or COMP)
Recall		<i>*RCL 0</i>	Recalls instrument state
Shift	Save	<i>*SAV 0</i>	Saves present instrument state
Shift	Error	<i>ERROR 0</i>	Displays errors in SCPI error queue
Meter		<i>12.000V 0.204A</i>	Measures output voltage and current
	▼	<i>12.500V MAX</i>	Measures peak output voltage ¹
	▼	<i>1.000V MIN</i>	Measures minimum output voltage ¹
	▼	<i>12.330V HIGH</i>	Measures the high level of a voltage pulse waveform ¹
	▼	<i>0.080V LOW</i>	Measures the low level of a voltage pulse waveform ¹
	▼	<i>12.000V RMS</i>	Measures rms voltage ¹
	▼	<i>0.350A MAX</i>	Measures peak output current ¹
	▼	<i>0.050A MIN</i>	Measures minimum output current ¹
	▼	<i>0.400A HIGH</i>	Measures the high level of a current pulse waveform ¹
	▼	<i>0.012A LOW</i>	Measures the low level of a current pulse waveform ¹
	▼	<i>0.210A RMS</i>	Measures rms current ¹
Voltage		<i>VOLT 20.000</i>	Sets the output voltage
Current		<i>CURR 2.000</i>	Sets the output current
Protect		<i>OC - - - -</i>	Protection status (example shows overcurrent tripped)
Output		<i>*RST</i>	Places the dc source in the factory-default state
	▼	<i>PON:STATE RST</i>	Select the power-on state command (RST or RCL0)
	▼	<i>PROT:DLY 0.08</i>	Sets the output protection delay in seconds
	▼	<i>RI LATCHING</i>	Sets the remote inhibit mode (LATCHING, LIVE, or OFF)
	▼	<i>DFI OFF</i>	Sets the discrete fault indicator state (ON or OFF)
	▼	<i>DFI:SOUR OFF</i>	Selects the DFI source (QUES, OPER, ESB, RQS, or OFF)
	▼	<i>PORT RIDFI</i>	Sets the output port functions (RIDFI or DIGIO)
	▼	<i>DIGIO 7</i>	Sets and reads the I/O port value (0 through 7)
	▼	<i>RELAY ON</i>	Sets the output relay state (ON or OFF) ²
	▼	<i>RELAY NORM</i>	Sets the output relay polarity (NORM or REV) ²
Shift	OV	<i>VOLT:PROT 22</i>	Sets overvoltage protection level
Shift	Input	<i>CURR:RANG HIGH</i>	Sets current range (HIGH, LOW, or AUTO)
	▼	<i>CURR:DET ACDC</i>	Sets current measurement detector (ACDC or DC) ¹
Shift	Cal	<i>CAL ON</i>	Accesses calibration menu (See User's Guide).

Use  and  to select menu parameters. Use **Meter** to exit any menu and return to metering mode.

¹Not available on Agilent 6611C – 6614C or in Compatibility mode.

²Not available on Agilent 66312A.

SCPI Programming Commands - At a Glance

NOTE Most [optional] commands have been omitted for clarity. Refer to the Programming Guide for a complete description of all programming commands.

ABORt

CALibrate

```
:CURRent [:POSitive]
:MEASure :LOWRange
:AC1

:DATA <n>
:LEVel P1 | P2 | P3 | P4
:PASSword <n>
:SAVE
:STATe <bool> [, <n>]
:VOLTage :PROTection
```

DISPlay

```
<bool>
:MODE NORMal | TEXT
:TEXT <display_string>
```

INITiate

```
:SEQuence[1|2]1
:NAME TRANSient | ACQUIRE1
:CONTInuous :SEQuence[1], <bool>
:NAME TRANSient, <bool>
```

MEASure | FETCh²

```
:ARRay :CURRent?1
:VOLTage?1
[:CURRent][:DC]?
:ACDC?1
:HIGH?1
:LOW?1
:MAX?1
:MIN?1
:VOLTage [:DC]?
:ACDC?1
:HIGH?1
:LOW?1
:MAX?1
:MIN?1
```

OUTPut

```
<bool>
:DFI <bool>
:SOURce QUES | OPER | ESB | RQS | OFF
:PON :STATe RST | RCLo
:PROTection :CLEar
:DELay <n>
:RELay [:STATe] <bool>3
:POLarity NORM | REV3
:RI :MODE LATCHing | LIVE | OFF
```

SENSE

```
:CURRent :RANGE <n>
:DETECTOR ACDC | DC1
:FUNCTion "VOLT" | "CURR"1
:SWEEP :OFFSet :POINTS <n>1
:POINTS <n>
:TINTERval <n>
[SOURCE:] CURRent <n>
:TRIGGERed <n>
:PROTection :STATe <bool>
DIGital :DATA <n>
:FUNCTion RIDF | DIG
VOLTage <n>
:TRIGGERed <n>
:PROTection <n>
```

STATus

```
:PRESet
:OPERation [:EVENT]?
:CONDition?
:ENABLE <n>
:NTRANSition <n>
:PTRANSition <n>
:QUESTIONable [:EVENT]?
:CONDition?
:ENABLE <n>
:NTRANSition <n>
:PTRANSition <n>
```

SYSTEM

```
:ERRor?
:LANGUage SCPI | COMPatibility
:VERSion?
:LOCAL
:REMOte
:RWLOCK
```

TRIGGER

```
:SEQuence 2 | :ACQUIRE [:IMMediate]1
:COUNT :CURRent <n>1
:VOLTage <n>1
:HYSteresis:CURRent <n>1
:VOLTage <n>1
:LEVel :CURRent <n>1
:VOLTage <n>1
:SLOPe :CURRent POS | NEG | EITH1
:VOLTage POS | NEG | EITH1
:SOURce BUS | INTERNAL1
[:SEQuence1 | :TRANSient][:IMMediate]
:SOURce BUS
:SEQuence1 :DEFine TRANSient
:SEQuence2 :DEFine ACQUIRE1
```

¹Not available on Agilent 6611C - 6614C.

²Fetch commands not available on Agilent 6611C - 6614C

³Not available on Agilent 66312A

The Rear Panel - At a Glance

① GPIB (IEEE-488) interface connector

② RS-232 interface connector

③ INH/FLT (remote INHibit / internal FauLT) connector. Connector plug is removable.

④ Output and Remote sense connector. Connector plug is removable.

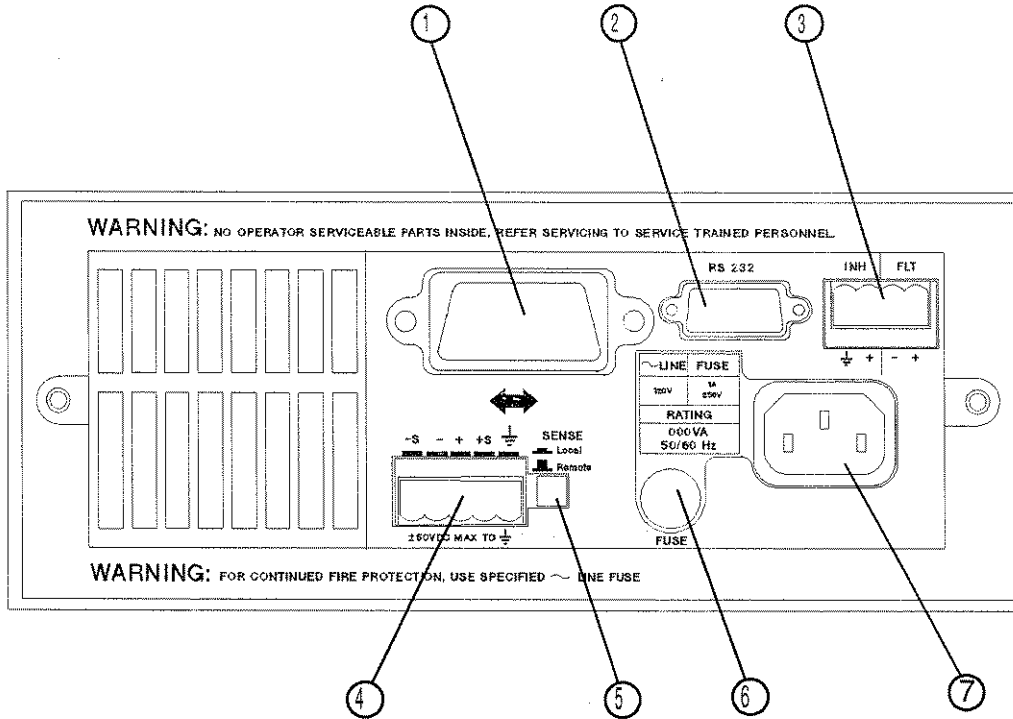

⑤ Remote or Local sense switch

⑥ Fuse holder

⑦ Power cord connector (IEC 320)

Use the front panel Address menu to

- ◆ Select the GPIB or RS-232 interface (see chapter 4 in User's Guide)
- ◆ Select the GPIB bus address (see chapter 4 in User's Guide)
- ◆ Configure the RS-232 interface (see chapter 4 in User's Guide)

General Information

Document Orientation

This manual describes the operation of the Agilent Model 66312A Dynamic Measurement DC Source and the Agilent Model 6611C, 6612C 6613C and 6614C System DC Power Supplies. Unless otherwise noted, all units will be referred to by the description "dc source" throughout this manual. The following documents and software are shipped with your dc source:

- ◆ a User's Guide (this document), contains installation, checkout, and front panel information
- ◆ a Programming Guide, contains detailed GPIB programming information

The following Getting Started Map will help you find the information you need to complete the specific task that you want to accomplish. Refer to the table of contents or index of each guide for a complete list of the information contained within.

Getting Started Map

Task	Where to find information
Installing the unit Line voltage connections Computer connections Load connections	User's Guide
Checking out the unit Verifying proper operation Using the front panel Calibrating the unit	User's Guide
Using the front panel Front panel keys Front panel examples	User's Guide
Using the programming interface GPIB interface RS-232 interface	User's Guide Programming Guide
Programming the unit using SCPI (and Compatibility) commands SCPI commands SCPI programming examples Compatibility language	Programming Guide
Installing the VXiplug&play instrument driver NOTE: The driver must be installed on your pc to access the on-line information. Drivers are available on the web at www.agilent.com/find/drivers .	Programming Guide

Safety Considerations

This dc source is a Safety Class 1 instrument, which means it has a protective earth terminal. That terminal must be connected to earth ground through a power source equipped with a ground receptacle. Refer to the Safety Summary page at the beginning of this guide for general safety information. Before installation or operation, check the dc source and review this guide for safety warnings and instructions. Safety warnings for specific procedures are located at appropriate places in the guide.

Options and Accessories

Table 2-1. Options

Option	Description
100	87–106 Vac, 47–63 Hz
220	191–233 Vac, 47–63 Hz
230	207–253 Vac, 47–63 Hz
760	Isolation and polarity reversal relays (not available on Agilent 66312A)
1CM ¹	Rack mount kit for one unit (p/n 5062-3972)
AXS ¹	Rack mount kit for 2 side-by-side units. Consists of: Lock-link kit (p/n 5061-9694) and Flange kit (p/n 5062-3974)
AXU	Rack mount and slide kit for 2 side-by-side units of different depth. Consists of: Support shelf (p/n 5062-3996) and Slide kit (p/n 1494-0015)
AXV	Rack mount, slide kit, and support shelf for mounting one unit. Consists of: Fill panel (p/n 5062-4022), Support shelf (p/n 5062-3996), and Slide kit (p/n 1494-0015)
0BN	Service manual with extra operating manuals

¹Support rails are required when rack mounting units. Use E3663A support rails for Agilent rack cabinets, and E3664A for non-Agilent rack cabinets.

Table 2-2. Accessories

Item	Part Number
GPIB cables	
1.0 meter (3.3 ft)	10833A
2.0 meters (6.6 ft)	10833B
4.0 meters (13.2 ft)	10833C
0.5 meters (1.6 ft)	10833D
RS-232 cable	34398A
(9-pin F to 9-pin F, 2.5 meter, null modem/printer cable with one 9-pin M to 25-pin F adapter)	
RS-232 adapter kit (contains 4 adapters)	34399A
9-pin M to 25-pin M for pc or printer	
9-pin M to 25-pin M for pc or printer	
9-pin M to 25-pin M for modem	
9-pin M to 9-pin M for modem	

Description

Both the Agilent 66312A Dynamic Measurement DC Source and the Agilent 6611C, 6612C, 6613C and 6614C System DC Power Supplies combine two instruments in one unit. They include a dc source, which produces dc output with programmable voltage and current amplitude, and a highly accurate voltage and current meter, with the capability to measure very low-level currents. Additionally, the Agilent 66312A Dynamic Measurement DC Source has the ability to measure and characterize output voltage and current of pulse or ac waveforms.

Capabilities

- ◆ Output Voltage and Current control with 12-bit programming resolution
- ◆ Extensive measurement capability:
 - dc voltage and current.
 - rms and peak voltage and current (Agilent 66312A only).
 - 16-bit measurement resolution (low range accurate down to 2 microamperes).
 - Triggered acquisition of digitized current and voltage waveforms (Agilent 66312A only).
- ◆ Front panel control with 14-character vacuum fluorescent display, keypad, and rotary control for voltage and current settings.
- ◆ Built-in GPIB and RS-232 interface programming with SCPI command language.
- ◆ Non-volatile state storage and recall with SCPI command language.
- ◆ Over-voltage, over-current, over-temperature, and RI/DFI protection features.
- ◆ Extensive selftest, status reporting, and software calibration.

Front Panel Controls

The front panel has both rotary (RPG) and keypad controls for setting the output voltage and current. The panel display provides digital readouts of a number of output measurements. Annunciators display the operating status of the dc source. System keys let you perform system functions such as setting the GPIB address and recalling operating states. Front panel Function keys access the dc source function menus. Front panel Entry keys let you select and enter parameter values. Refer to chapter 5 for a complete description of the front panel controls.

Remote Programming

NOTE: When shipped, all units are set to the SCPI programming language. The language setting is saved in non-volatile memory.

To change the programming language from SCPI to Compatibility language, press the front panel **Address** key, use ▼ to scroll to the LANG command, press ↓ to select SCPI, then press **Enter**. Refer to the Programming Guide supplied with your dc source for further information about remote programming.

The dc source may be remotely programmed via the GPIB bus and/or from an RS-232 serial port. GPIB programming is with SCPI commands (Standard Commands for Programmable Instruments), which make the dc source programs compatible with those of other GPIB instruments. Compatibility commands are also included to make the dc source compatible with the Agilent 6632A, 6633A, and 6634A Series dc power supplies (refer to appendix D in the the Programming Guide). Dc source status registers allow remote monitoring of a wide variety of dc source operating conditions.

2 - General Information

Output Characteristic

The dc source's output characteristic is shown in the following figure. The output of the dc source may be adjusted to any value within the boundaries shown.

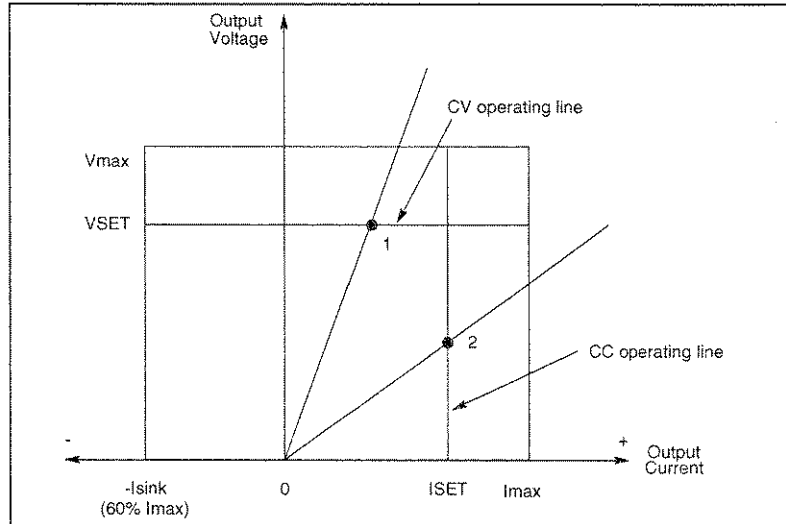

Figure 2-1. Dc Source Output Characteristic

The dc source can operate in either constant voltage (CV) or constant current (CC) over the rated output voltage and current. Although the dc source can operate in either mode, it is designed as a *constant voltage* source. This means that the unit turns on in constant voltage mode with the output voltage rising to its V_{set} value. There is no command for constant current operation. The only way to turn the unit on in constant current mode is by placing a short across the output and then enabling or turning the output on.

Note that the dc source cannot be programmed to operate in a specific mode. After initial turn-on, the operating mode of the unit will be determined by the voltage setting, the current setting, *and* the load resistance. In figure 2-1, operating point 1 is defined by the load line traversing the positive operating quadrant in the constant voltage region. Operating point 2 is defined by the load line traversing the positive operating quadrant in the constant current region.

Figure 2-1 also shows a single range – two quadrant capability. This means that the dc source is capable of sourcing as well as sinking current over the output voltage range from zero volts to the rated maximum. The negative current sinking capability of the dc source is not programmable, and is fixed at a maximum of approximately 60% of I_{max} .

NOTE: If you attempt to operate the dc source beyond its output ratings, the output of the unit will become unregulated. This is indicated by the UNR annunciator on the front panel. The output may also become unregulated if the ac input voltage drops below the minimum rating specified in Appendix A.

Appendix A documents the dc source's specifications and supplemental characteristics.

Installation

Inspection

Damage

When you receive your dc source, inspect it for any obvious damage that may have occurred during shipment. If there is damage, notify the shipping carrier and the nearest Agilent Sales and Support Office immediately. The list of Agilent Sales and Support Offices is at the back of this guide. Warranty information is printed in the front of this guide.

Packaging Material

Until you have checked out the dc source, save the shipping carton and packing materials in case the unit has to be returned. If you return the dc source for service, attach a tag identifying the model number and the owner. Also include a brief description of the problem.

Items Supplied

The following user-replaceable items are included with your dc source. Some of these items are installed in the unit.

Table 3-1. Items Supplied

Item	Part Number	Description
Power Cord	contact nearest Agilent Sales and Support Office	A power cord appropriate for your location.
Digital connector	1252-1488	A 4-terminal digital plug that connects to the back of the unit.
Output connector	0360-2604	A 5-terminal plug that connects to the back of the unit.
Line Fuse	2110-0633 2110-0788	2.5 AT (time delay) for 100/120 Vac operation 1.25 AT (time delay) for 220/230 Vac operation
Feet	5041-8801	feet for bench mounting
User's Guide	5962-8194	Contains installation, checkout, and front panel information.
Programming Guide	5962-8198	Contains detailed GPIB programming information.

Cleaning

Use a dry cloth or one slightly dampened with water to clean the external case parts. Do not attempt to clean internally.

WARNING: To prevent electric shock, unplug the unit before cleaning.

Location

Figure 3-1 gives the dimensions of your dc source. The dc source must be installed in a location that allows sufficient space at the sides and back for adequate air circulation (see Bench Operation).

NOTE: This dc source generates magnetic fields that may affect the operation of other instruments. If your instrument is susceptible to operating magnetic fields, do not locate it in the immediate vicinity of the dc source. Typically, at three inches from the dc source, the electromagnetic field is less than 5 gauss. Many CRT's, such as those used in computer displays, are susceptible to magnetic fields much lower than 5 gauss. Check susceptibility before mounting any display near the dc source.

Bench Operation

A fan cools the dc source by drawing air in through the sides and exhausting it out the back. Minimum clearances for bench operation are 1 inch (25 mm) along the sides.

Do not block the fan exhaust at the rear of the unit.

Rack Mounting

The dc source can be mounted in a standard 19-inch rack panel or cabinet. Table 2-1 documents the Agilent part numbers for the various rack mounting options that are available for the dc source. Installation instructions are included with each rack mount option.

NOTE: Support rails or an instrument shelf is required when rack mounting units.

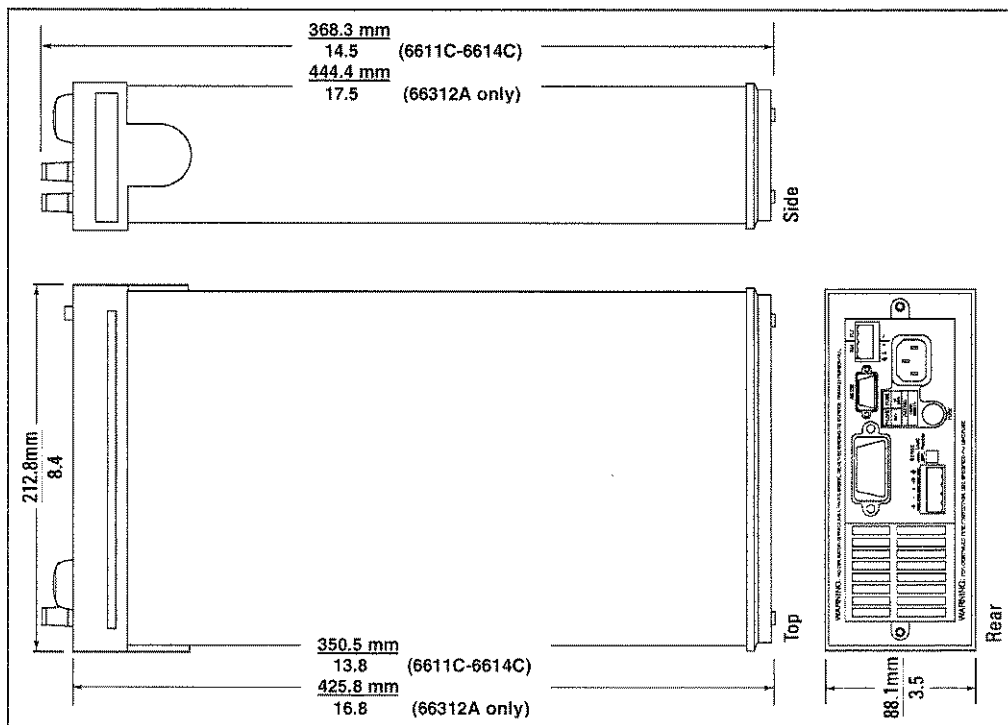

Figure 3-1. Outline Diagram

Input Connections

Connect the Power Cord

1. Unscrew the line fuse cap from the rear panel and verify that the fuse rating matches what is specified on the FUSES label on the rear panel. Reinstall the fuse. (See table 3-1 for fuse part numbers.)
2. Connect the power cord to the IEC 320 connector on the rear of the unit. If the wrong power cord was shipped with your unit, contact your nearest Agilent Sales and Support Office (refer to the list at the back of this guide) to obtain the correct cord.

Output Connections

The output connector has a termination for the + and – output, the + and – sense terminals, and an earth ground terminal. The 5-pin connector is removable and accepts wires sizes from AWG 22 to AWG 12. Disconnect the mating plug from the unit by pulling it straight back.

Front panel binding posts are available to connect load wires for bench operation. The front panel binding posts are paralleled with the rear panel + and – connections. *Before using the front panel binding posts, make sure that the sense switch on the back of the unit is set to **Local**.*

NOTE: Front panel binding posts are provided for convenience. Only the rear panel terminals are optimized for noise, regulation, and transient response as documented in Appendix A.

Wire Considerations

To minimize the possibility of instability on the output,

- ◆ keep load leads as short as possible
- ◆ bundle or twist the leads tightly together to minimize inductance

Current Ratings

Fire Hazard To satisfy safety requirements, load wires must be large enough not to overheat when carrying the maximum short-circuit current of the dc source. If there is more than one load, then any pair of load wires must be capable of safely carrying the full-rated current of the dc source.

The following table lists the characteristics of AWG (American Wire Gage) copper wire.

Table 3-2. Ampacity and Resistance of Stranded Copper Conductors

AWG No.	Ampacity (in free air)	Resistance (at 20 deg. C)	
		Ω/m	Ω/ft
20	8.33	0.0345	0.01054
18	15.4	0.0217	0.00663
16	19.4	0.0137	0.00417
14	31.2	0.0086	0.00262
12	40	0.0054	0.00165

3 - Installation

Voltage Drops

The load wires must also be large enough to avoid excessive voltage drops due to the impedance of the wires. In general, if the wires are heavy enough to carry the maximum short circuit current without overheating, excessive voltage drops will not be a problem. The voltage drops across the load wires should be limited to less than two volts. Refer to Table 3-2 to calculate the voltage drop for some commonly used AWG copper wire.

Multiple Load Connections

When the unit is in local sensing mode and you are connecting multiple loads to the output, connect each load to the output terminals using separate load leads. This minimizes mutual coupling effects and takes full advantage of the dc source's low output impedance. Each pair of wires should be as short as possible and twisted or bundled to reduce lead inductance and noise pickup.

If cabling considerations require the use of distribution terminals that are located remotely from the dc source, connect the dc source's output terminals to the remote distribution terminals by a pair of twisted or bundled wires. Connect each load to the distribution terminals separately. Remote voltage sensing is recommended under these circumstances. Sense either at the remote distribution terminals, or if one load is more sensitive than the others, sense directly at the critical load.

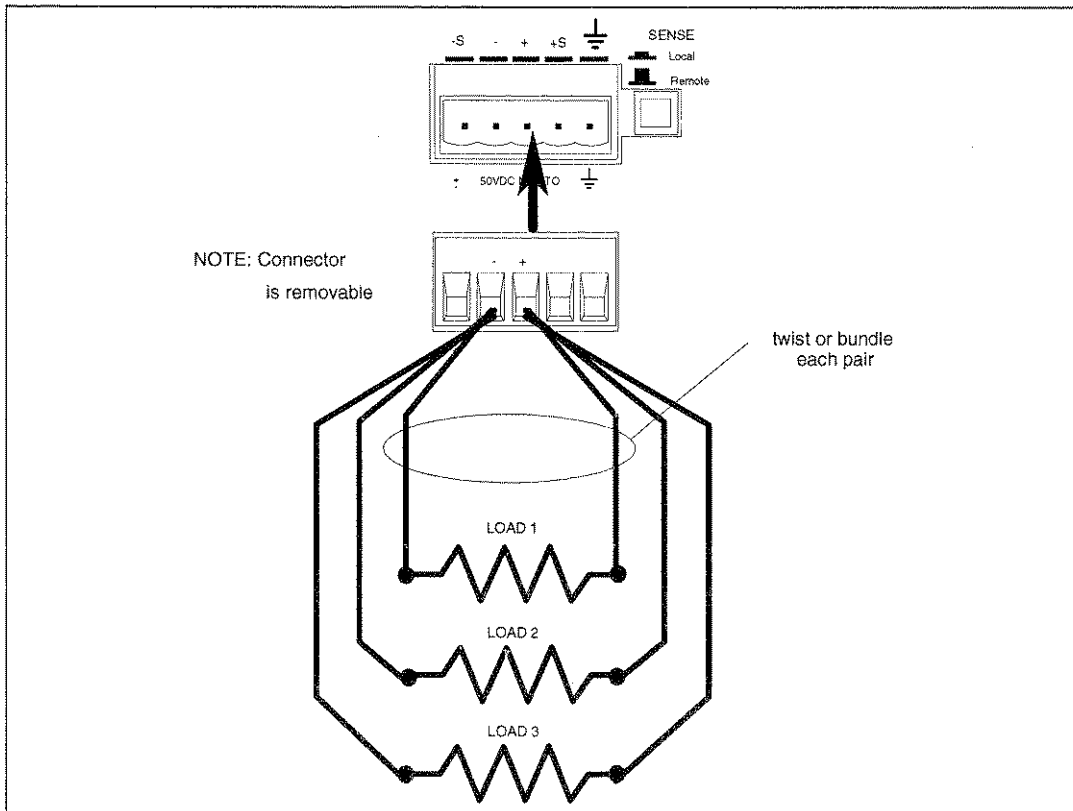

Figure 3-2. Multiple Load Connections

Remote Sense Connections

Under normal operation, the dc source senses the output voltage at the output terminals on the back of the unit. External sense terminals are available on the **back** of the unit that allow the output voltages to be sensed at the load, compensating for impedance losses in the load wiring. *You cannot remote sense at the front panel binding posts.*

The output connector accepts wires sizes from AWG 22 to AWG 12. Disconnect the mating plug to make your wiring connections. When the sense wire connections are complete, set the Remote/Local switch on the back of the unit to Remote (switch is out).

Sense Leads

The sense leads are part of the dc source's feedback path and must be kept at a low resistance (less than several ohms) to maintain optimal performance. Connect the sense leads carefully so that they do not become open-circuited. If the sense leads are left unconnected or become open during operation, the dc source will regulate at the output terminals, resulting in a 3% to 5% increase in output over the programmed value. Shorting the sense leads trips the OVP circuit.

NOTE: It is good engineering practice to twist and shield all signal wires to and from the sense connectors. Connect the shield at the dc source end only. Do not use the shield as one of the sensing conductors.

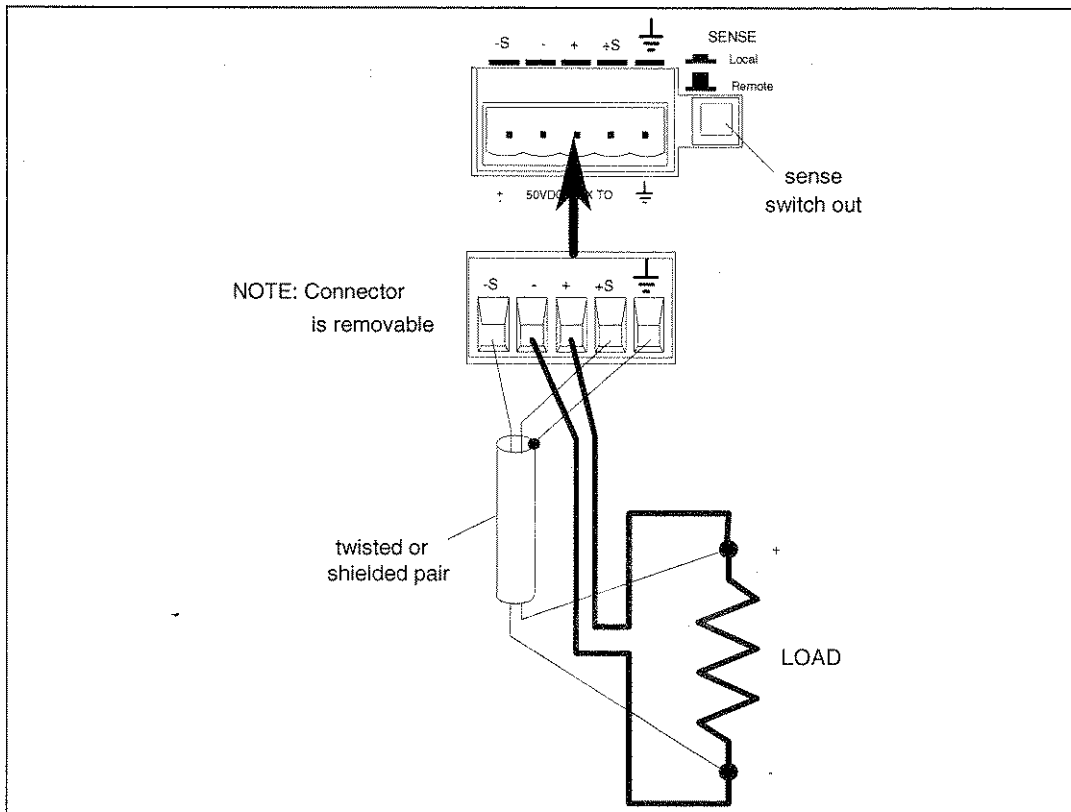

Figure 3-3. Remote Sense Connections

3 - Installation

The overvoltage protection circuit senses voltage near the output terminals, not at the load. Therefore the signal sensed by the OVP circuit can be significantly higher than the actual voltage at the load. When using remote sensing, you must program the OVP trip voltage high enough to compensate for the voltage drop between the output terminals and the load. Also, if the sum of the programmed voltage and the load-lead drop exceeds the dc source's maximum voltage rating, this may also trip the OV protection circuit.

Stability

When the unit is configured for remote sensing, it is possible for the impedance of the load wires and the capacitance of the load to form a filter, which becomes part of the unit's feedback loop. This can degrade the unit's stability and result in poor transient response performance. In extreme cases it may also cause oscillations. The wiring guidelines previously discussed under "Wire Considerations" will eliminate most stability problems associated with load lead inductance. If additional measures are required:

- ◆ keep the load capacitance as small as possible
- ◆ use larger diameter load wires to reduce resistance

OVP Considerations

The dc source's OVP circuit contains a crowbar SCR, which effectively shorts the output of the dc source whenever the OVP trips. If an external voltage source such as a battery is connected across the output and the OVP is inadvertently triggered, the SCR will continuously sink a large current from the battery, possibly damaging the dc source.

To avoid this, program the OVP setting to its maximum value to prevent it from inadvertently tripping. Additionally, an internal fuse is connected in series with the SCR. This fuse will open to prevent large currents from damaging the SCR. If this internal fuse has opened, The FS status annunciator will be set. Refer to the Service Manual for instructions about replacing this fuse.

In addition, the OVP circuit's SCR crowbar has been designed to discharge capacitances up to a specific limit. This limit is:

Agilent 6611C	127,000 μ F.	Agilent 6613C	20,000 μ F.
Agilent 6612C and 66312A	50,000 μ F.	Agilent 6614C	10,000 μ F.

If your load capacitance approaches this limit, it is recommended that you do not intentionally trip the OVP and discharge the capacitance through the SCR as part of your normal testing procedure, as this may lead to long-term failure of some components.

INH/FLT Connections

This rear panel connector, has a fault output port and an inhibit input port. The fault (FLT) output, also referred to as the DFI (discrete fault indicator) signal in the front panel and SCPI commands, is an open collector circuit that pulls the positive output low with respect to the negative (chassis-referenced) common. The high impedance inhibit (INH) input, also referred to as the RI (remote inhibit) signal in the front panel and SCPI commands, is used to shut down the power supply output whenever the INH + is pulled low with respect to the INH (chassis-referenced) common.

The connector accepts wires sizes from AWG 22 to AWG 12. Disconnect the mating plug to make your wire connections.

NOTE: It is good engineering practice to twist and shield all signal wires to and from the digital connectors. If shielded wire is used, connect only one end of the shield to chassis ground to prevent ground loops.

Figure 3-4 shows how you can connect the FLT/INH circuits of the dc source.

In example A, the INH input connects to a switch that shorts the Inhibit pin (+) to common whenever it is necessary to disable output of the unit. This activates the remote inhibit (RI) circuit, which turns off the dc output. The front panel Prot annunciator comes on and the RI bit is set in the Questionable Status Event register. To re-enable the unit, first open the connection between pins INH + and common and then clear the protection circuit. This can be done either from the front panel or over the GPIB/RS-232.

In example B, the FLT output of one unit is connected to the INH input of another unit. A fault condition in one of the units will disable all of them without intervention either by the controller or external circuitry. The controller can be made aware of the fault via a service request (SRQ) generated by the Questionable Status summary bit. Note that the FLT output can also be used to drive an external relay circuit or signal other devices whenever a user-definable fault occurs.

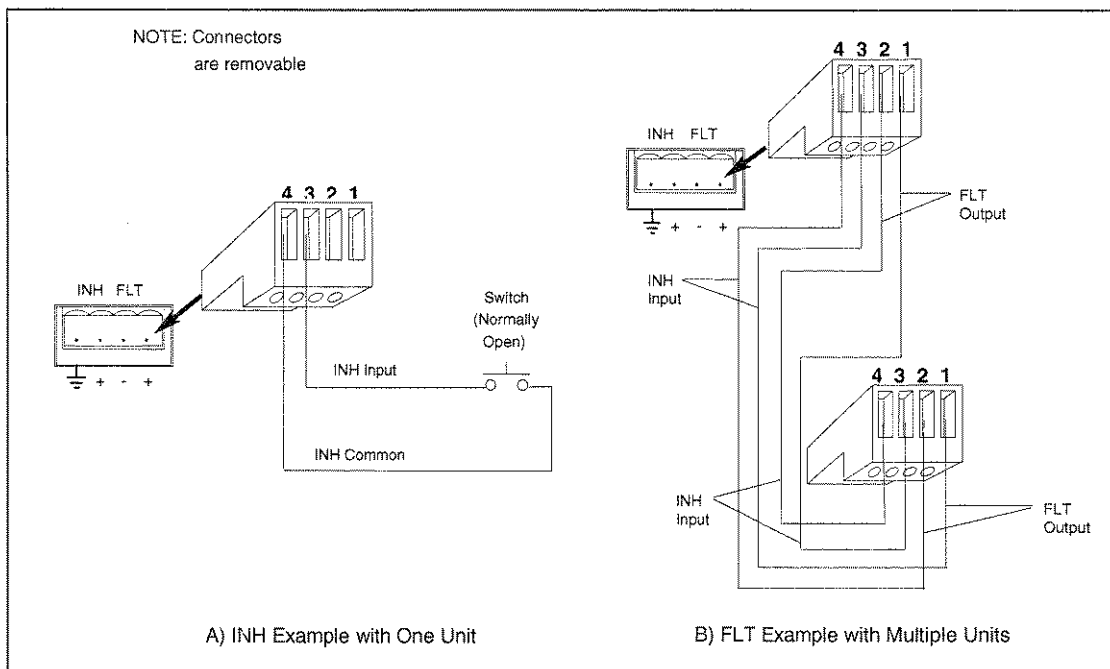

e 3-4. FLT/INH Examples

Figur

3 - Installation

Digital I/O Connections

As shown in Table 3-3 and Figure 3-5, the FLT/INH connector can also be configured as a digital I/O port. Information on programming the digital I/O port is found in chapter 5 and under [SOURCE:]DIGital:DATA and [SOURCE:]DIGital:FUNCTION commands in the Programming Guide. The electrical characteristics of the digital connector are described in appendix A.

Table 3-3. FLT/INH DIGital I/O Connector

PIN	FAULT/INHIBIT	DIGITAL I/O
1	FLT Output	Output 0
2	FLT Common	Output 1
3	INH Input	Input/Output 2
4	INH Common	Common

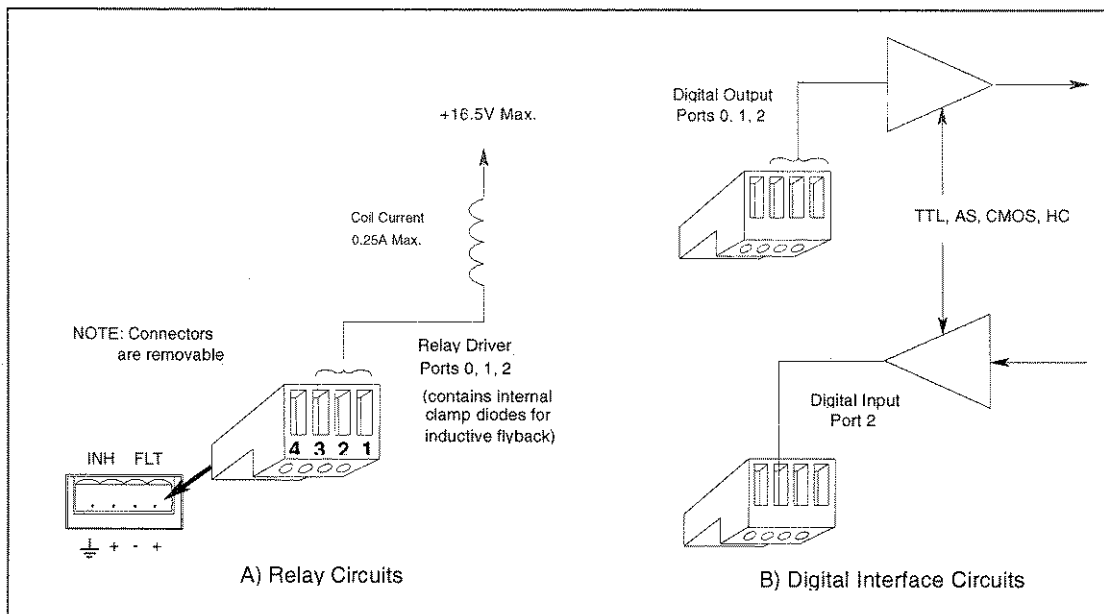

Figure 3-5. Digital I/O Examples

Controller Connections

The dc source connects to a controller either through an GPIB or an RS-232 connector.

GPIB Interface

Each dc source has its own GPIB bus address, which can be set using the front panel **Address** key as described in chapter 5. GPIB address data is stored in non-volatile memory. The dc source is shipped with its GPIB address set to 5.

Dc sources may be connected to the GPIB interface in series configuration, star configuration, or a combination of the two, provided the following rules are observed:

- ◆ The total number of devices including the controller is no more than 15.
- ◆ The total length of all cables used is no more than 2 meters times the number of devices connected together, up to a maximum of 20 meters. (Refer to table 2-2 for a list of GPIB cables available from Agilent Technologies.)
- ◆ Do not stack more than three connector blocks together on any GPIB connector.
- ◆ Make sure all connectors are fully seated and the lock screws are firmly finger-tightened.

RS-232 Interface

The dc source has an RS-232 programming interface, which is activated by commands located in the front panel **Address** menu. All SCPI and COMPAtibility commands are available through RS-232 programming. When the RS-232 interface is selected, the GPIB interface is disabled.

The RS-232 connector is a DB-9, male connector. Adapters are available to connect the dc source to any computer or terminal with a properly configured DB-25 connector (see Table 2-2).

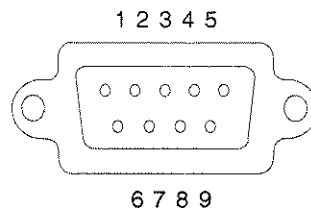

Figure 3-6. RS-232 Connector

Pin	Input/Output	Description
1	-	no connection
2	Input	Receive Data (RxD)
3	Output	Transmit Data (TxD)
4	Output	Data Terminal Ready (DTR)
5	Common	Signal ground
6	Input	Data Set Ready (DSR)
7	Output	Request to Send (RQS)
8	Input	Clear to Send (CTS)
9	-	no connection















Turn-On Checkout

Introduction

Successful tests in this chapter provide a high degree of confidence that the dc source is operating properly. For verification tests, see appendix B. Complete performance tests are given in the Service Guide.

NOTE: This chapter provides a preliminary introduction to the dc source front panel. See chapter 5 for more details.

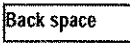
Using the Keypad

-  (shift) Some of the front panel keys perform two functions, one labeled in black and the other in blue. You access the blue function by first pressing the blue  shift key. Release the key after you press it. The **Shift** annunciator will be on, indicating that you have access to any key's shifted function.
-  Used to access a third level key function, the numeric entry keys. These third level function keys are labeled in green.
-  and  These keys let you scroll up and down through the choices in the presently selected function menu. All menu lists are circular; you can return to the starting position by continuously pressing either key.
-  and  These keys let you select the previous or the next parameter for a specific command. If the command has a numeric range, these keys increment or decrement the existing value. In meter mode, these keys can be used to adjust the magnitude of the output voltage or current. Only the flashing digit is changed by these keys. Use the  and  keys to move the flashing digit.
-  and  These **Entry** keys move the flashing digit in a numeric entry field to the right or left. This lets you increment or decrement a specific digit in the entry field using the  and  keys or the rotary control knob.
-  The backspace key is an erase key. If you make a mistake entering a digit and have not yet pressed **Enter**, you can delete the digit by pressing **Backspace**. Delete more digits by repeatedly pressing this key.
-  Executes the entered value or parameter of the presently accessed command. Until you press this key, the parameters you enter with the other keys are displayed but not entered into the dc source. After pressing **Enter**, the dc source returns to Meter mode.

Checkout Procedure

The tests in this section checks for output voltage and current on the dc source.

NOTE: To perform the checkout procedure, you will need a wire for shorting the output terminals together.

The following procedure assumes that the unit turns on in the factory-default state. If you need more information about the factory default state, refer to the *RST command in chapter 4 of the Programming Guide. Note that the values shown in the Display column may not exactly match the values that appear on the front panel of your unit.

If you have not already done so, connect the power cord to the unit and plug it in.

Table 4-1. Checkout Programming Values

Model	Voltage	OV Prot	Current	Note:
6611C	8	12	5	The checkout procedure is written for models 6612C and 66312A. If you have another model, enter the correct values from the table where the procedure calls for an <input>.
6612C/66312A	20	22	2	
6613C	50	55	1	
6614C	100	110	0.5	

Procedure	Display	Explanation
1. Turn the unit on. The dc source undergoes a self-test when you first turn it on.	***** ADDRESS 5 0.002V .0006A	During selftest, all display segments are briefly lit, followed by the GPIB Address. The display then goes into meter mode with the Dis annunciator on, and all others off. In Meter mode the *****V digits indicate the output voltage and the *****A digits indicate the output current. The flashing digit on the display indicates the digit that will be affected if changes are made to the displayed values using the rotary control or the ↑ and ↓ keys. You will only see the changes if the output is ON.

NOTE: Press the Meter key to exit a menu at any time and return to meter mode. If the Err annunciator on the display is on, press the **Shift** key followed by the **Error** key to see the error number. See table 4-2 at the end of this chapter.

2. Check that the dc source fan is on		You should be able to hear the fan and feel the air coming from the back of the unit.
3. Press Voltage , Enter Number , <2, 0>, Enter	VOLT 0.000 VOLT <20>	Programs the output to 20 volts. After the value is entered, the display returns to Meter mode. Because the output has not been enabled, the meter still indicates approximately 0 volts.
4. Press Output On/Off	<20.003>V 0.0006A	Turns the output on. The Dis annunciator should be off and CV should be on.
5. Press Shift , OV	VOLT:PROT <22.00>	Display shows the overvoltage protection trip voltage for your unit.

Procedure	Display	Explanation
6. Press Enter Number, 8, Enter	VOLT:PROT 8	Programs the OVP to 8 volts, which is less than the previously set output voltage.
	0.449V 0.145A	Because the OVP voltage entered was less than the output voltage, the OVP circuit tripped. The output dropped to zero, CV turned off, and Prot turned on.
7. Press Shift, OV, Enter Number, <2, 2>, Enter	VOLT:PROT <22>	Programs the OVP to a value greater than the output voltage setting of the unit. This prevents the OV circuit from tripping again when the protection condition is cleared.
8. Press Shift, Prot Clear	<20.003>V 0.0034A	Clears the protection condition, thus restoring the output of the unit. Prot turns off and CV turns on.
9. Press Output on/off		Turn the output off.
10. Connect a jumper wire across the + and - output terminals.		Shorts the output of the unit.
11. Press Output on/off .	0.0005V <0.2005>A	The CC annunciator is on, indicating that the unit is in constant current mode. The unit is sourcing output current at 10% of the maximum rating (the default output current limit setting).
12. Press Current, Enter Number, <2>, Enter .	0.0452V <1.998>A	Programs the output current to <2> ampere.
13. Press Shift, OCP	0.0005V 0.0003A	You enabled the overcurrent protection circuit. The circuit then tripped because the unit was operating in constant current mode. The CC annunciator turns off and the OCP and Prot annunciators come on.
14. Press Shift, OCP	0.0005V 0.0003A	You have disabled the overcurrent protection circuit. The OCP annunciator turns off.
15. Press Shift, Prot Clear	0.0452V <1.998>A	Restores the output. The Prot annunciator turns off. CC is on.
16. Turn the unit off and remove the shorting wire from the output terminals.		The next time the unit turns on it will be restored to the *RST or factory default state.

In Case of Trouble

Error Messages

Dc source failure may occur during power-on selftest or during operation. In either case, the display may show an error message that indicates the reason for the failure.

Selftest Errors

Pressing the **Shift, Error** keys will show the error number. Selftest error messages appear as: ERROR <n> where "n" is a number listed in the following table. If this occurs, turn the power off and then back on to see if the error persists. If the error message persists, the dc source requires service.

Table 4-2. Power-On Selftest Errors

Error No.	Failed Test
Error 0	No error
Error 1	Non-volatile RAM RDO section checksum failed
Error 2	Non-volatile RAM CONFIG section checksum failed
Error 3	Non-volatile RAM CAL section checksum failed
Error 4	Non-volatile RAM STATE section checksum failed
Error 5	Non-volatile RST section checksum failed
Error 10	RAM selftest
Error 11 to 14	VDAC/IDAC selftest 1 to 4
Error 15	OVDAC selftest
Error 80	Digital I/O selftest error

Runtime Error Messages

Appendix C lists other error messages that may appear at runtime. If the front panel display shows **OVL**, this indicates that the output voltage or current is beyond the range of the meter readback circuit. If the front panel display indicates -- -- -- -- --, an GPIB measurement is in progress.

Line Fuse

If the dc source appears "dead" with a blank display and the fan not running, check your power source to be certain line voltage is being supplied to the dc source. If the power source is normal, the dc source fuse may be defective.

1. Turn off the front panel power switch and unplug the power cord.
2. Remove the fuse from the rear panel.
3. If the fuse is defective, replace it with a fuse of the same type (see "Input Connections" in chapter 3).
4. Turn on the dc source and check the operation.

NOTE: If the dc source has a defective fuse, replace it only once. If it fails again, the dc source requires service.

Front panel Operation

Introduction

Here is what you will find in this chapter:

- ◆ a complete description of the front panel controls
- ◆ front panel programming examples

NOTE: The dc source must be in set to Local mode to use the front panel controls. Press the **Local** key on the front panel to put the unit in local mode.

Front Panel Description

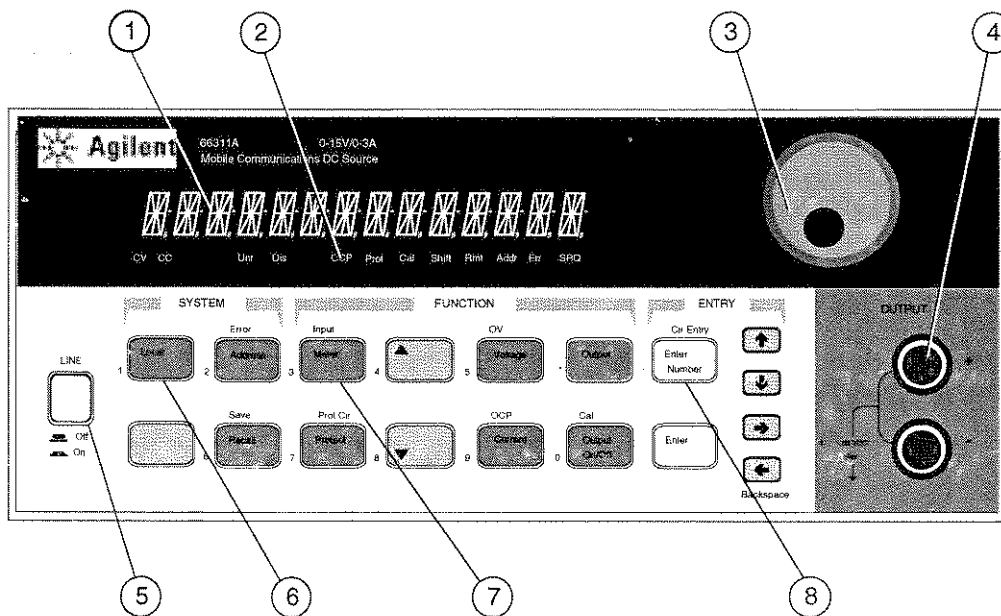

Figure 5-1. Front Panel, Overall View

5 - Front Panel Operation

- ① **Display** 14-character vacuum fluorescent display for showing output measurements and programmed values.
- ② **Annunciators** Annunciators light to indicate operating modes and status conditions:
 - CV** The dc source output is in constant-voltage mode.
 - CC** The dc source output is in constant-current mode.
 - Unr** The dc source output is in an unregulated state.
 - Dis** The dc source output is disabled (off).
 - OCP** The overcurrent protection state is enabled.
 - Prot** One of the dc source's output protection features is activated.
 - Cal** The dc source is in calibration mode.
 - Shift** The Shift key is pressed to access an alternate key function.
 - Rmt** The selected interface (GPIB or RS-232) is in a remote state.
 - Addr** The interface is addressed to talk or to listen.
 - Err** There is a message in the SCPI error queue.
 - SRQ** The interface is requesting service from the controller.
- ③ **Rotary Control** The rotary control lets you set the output voltage or current as well as menu parameters. Press ← and → to select the resolution, then adjust the value with the knob.
- ④ **Output Connectors** Front panel binding posts let you connect loads to the front of the unit. Before using the front panel binding posts, make sure that the sense switch on the back of the unit is set to Local.
- ⑤ **Line** This turns the dc source on or off.
- ⑥ **System Keys** The system keys let you:
 - Return to Local mode (front panel control)
 - Set the dc source GPIB address
 - Set the RS-232 interface communication baud rate and parity bit
 - Display SCPI error codes and clear the error queue
 - Save and recall up to 4 instrument operating configurations
- ⑦ **Function Keys** Function access command menus that let you:
 - Enable or disable the output
 - Select metering functions
 - Program output voltage and current
 - Display the protection status state
 - Set and clear protection functions
 - Set the output state at power-on
 - Calibrate the dc source
 - ▲ and ▼ scroll through the front panel menu commands
- ⑧ **Entry Keys** Entry keys let you:
 - Enter programming values
 - Increment or decrement programming values
 - ↑ and ↓ select the front panel menu parameters

System Keys

Refer to the examples later in this chapter for more details on the use of these keys.

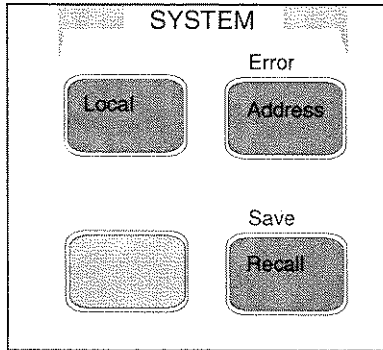



Figure 5-2. System Keys



This is the blue, unlabeled key, which is also shown as  in this guide. Pressing this key accesses the alternate or shifted function of a key (such as **ERROR**). Release the key after you press it. The **Shift** annunciator is lit, indicating that the shifted keys are active.



Press to change the dc source's selected interface from remote operation to local (front panel) operation. Pressing the key will have no effect if the interface state is already Local, Local-with-Lockout, or Remote-with-Lockout.







Press to access the system address menu. This menu lets you configure the dc source's interface. Address Menu entries are stored in non-volatile memory.

Display	Command Function
ADDRESS <value>	Sets the GPIB Address
INTF <char>	Selects an interface (GPIB or RS232)
BAUDRATE<value>	Selects baud rate (300, 600, 1200, 2400, 4800, 9600)
PARITY <char>	Message parity (NONE, EVEN, ODD, MARK, SPACE)
FLOW <char>	Flow control (XON-XOFF, RTS-CTS, DTR-DSR, NONE)
LANG <char>I	Selects language (SCPI or COMP)

value = a numeric value

char = a character string parameter

Use  and  to scroll through the command list.

Use  and  to scroll through the parameter list.



Press to place the dc source into a previously stored state. You can recall up to 4 (0 through 3) previously stored states.



Press to display the system error codes stored in the SCPI error queue. This action also clears the queue. If there is no error in the queue, 0 is displayed.



Press to store an existing dc source state in non-volatile memory. The parameters saved are listed under *SAV in the dc source Programming Guide. You can save up to 4 states (0 through 3).

Function Keys

Refer to the examples later in this chapter for more details on the use of these keys.

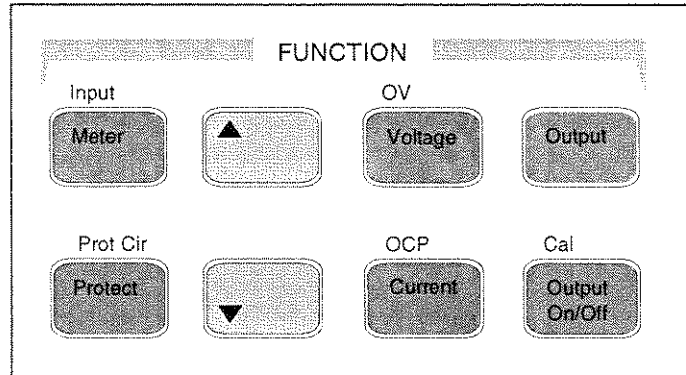

Figure 5-3. Function Keys

Immediate Action Keys

Immediate action keys immediately execute their corresponding function when pressed. Other function keys have commands underneath them that are accessed when the key is pressed.

Output On/Off

This key toggles the output of the dc source between the on and off states. It immediately executes its function as soon as you press it. When off, the dc source output is disabled and the **Dis** annunciator is on.

Shift Prot Cir

Press this key to reset the protection circuit and allow the unit to return to its last programmed state. The condition that caused the protection circuit to become active must be removed prior to pressing this key, or the unit will shut down again and display the **Prot** annunciator again. (If **FS** protection is displayed on the front panel, the unit must be opened and an internal fuse replaced as described in the Service manual.)

Shift OCP

Press this key to toggle between OCP enabled and disabled. If OCP is enabled the output will become disabled if the output mode changes from **CV** to **CC** mode. The OCP annunciator indicates the state of OCP.

Scrolling Keys

Scrolling keys let you move through the commands in the presently selected function menu.

▲ ▼

Press **▼** to bring up the next command in the list. Press **▲** to go back to the previous command in the list. Function menus are circular; you can return to the starting position by continuously pressing either key. The following example shows the commands in the Input function menu:

▼ CURR:RANGE <char>
▼ CURR:DET <char>

Metering Keys

Metering keys control the metering functions of the dc source. When the unit is operating in front panel meter mode, all front panel measurements are calculated from a total of 2048 readings taken at a 46.8 microsecond sampling rate. Therefore, the total acquisition time for a single front panel measurement is about 100 milliseconds. Refer to “Making Front Panel Measurements” for more information.

NOTE: You can vary the both the sampling rate and the number of data points in each measurement when controlling the unit over the GPIB interface. (Refer to chapter 3 in the Programming Guide).

Meter

Press this key to access the meter menu list. Also use this key to exit a menu at any time and return to meter mode.

Display	Measurement
<reading>V <reading>A	Measures output dc voltage and current
<reading>V MAX	Measures peak output voltage ¹
<reading>V MIN	Measures minimum output voltage ¹
<reading>V HIGH	Measures the high level of a voltage pulse waveform ¹
<reading>V LOW	Measures the low level of a voltage pulse waveform ¹
<reading>V RMS	Measures rms voltage ¹
<reading>A MAX	Measures peak output current ¹
<reading>A MIN	Measures minimum output current ¹
<reading>A HIGH	Measures the high level of a current pulse waveform ¹
<reading>A LOW	Measures the low level of a current pulse waveform ¹
<reading>A RMS	Measures rms current ¹

Shift

Input

Press this key to access the following metering functions.

Display	Command Function
CURR:RANGE <char>	Select current range (AUTO, LOW or HIGH)
CURR:DET <char>	Select current measurement bandwidth (ACDC or DC) ¹



Notes:



¹Not available on Agilent 6611C - 6614C or in Compatibility mode



reading = the returned measurement

value = a numeric value

char = a character string parameter

Use  and  to scroll through the menu commands.

Use  and  to scroll through the menu parameters.

Use  and  to select a digit in a numeric entry field.

5 - Front Panel Operation

Output Control Keys

Output control keys control the output functions of the dc source.

Voltage

Press this key to access the voltage menu.

Display	Command Function
---------	------------------

VOLT <value>	Sets the output voltage
--------------	-------------------------

Current

Press this key to access the current menu.

Display	Command Function
---------	------------------

CURR <value>	Sets the output current
--------------	-------------------------

Output

Press this key to access the output menu list.

Display	Command Function
---------	------------------

*RST	Places the dc source in the factory-default state
------	---

PON:STATE <char>	Select the power-on state command (RST or RCL0) ¹
------------------	--

RI <char>	Sets the remote inhibit mode (LATCHING, LIVE, or OFF) ¹
-----------	--

DFI <char>	Sets the discrete fault indicator state (ON or OFF)
------------	---

DFI:SOUR <char>	Selects the DFI source (QUES, OPER, ESB, RQS, or OFF) ²
-----------------	--

PORT <char>	Sets the output port functions (RIDFI or DIGIO) ¹
-------------	--

DIGIO <char>	Sets and reads the I/O port value (0 through 7)
--------------	---

RELAY <char>	Set relay state independent of output ("ON" or "OFF" ³)
--------------	---

REL:POL <char>	Set relay polarity ("NORM" or "REV" ³)
----------------	--

PROT:DLY <value>	Sets the output protection delay in seconds
------------------	---

Protect

Press this key to display protection status.

Display	Command Function
---------	------------------

OC OT OV RI FS	Status of the protection features (example shows all tripped)
----------------	---

-- -- -- -- --	Status of the protection features (example shows none tripped)
----------------	--

Shift

OV

Press this key to access the overvoltage protection menu.

Display	Command Function
---------	------------------

VOLT:PROT <value>	Sets overvoltage protection level
-------------------	-----------------------------------

Shift

Cal

This key accesses the calibration menu (Refer to Appendix B for details).



Notes: ¹These parameters are stored in non-volatile memory



²These status summary bits are explained in chapter 3 of the Programming Guide



³Not available on Agilent 66312A

value = a numeric value

char = a character string parameter

Use  and  to scroll through the menu commands.

Use  and  to scroll through the menu parameters.

Use  and  to select a digit in a numeric entry field.

Entry Keys

Refer to the examples later in this chapter for more details on the use of these keys.

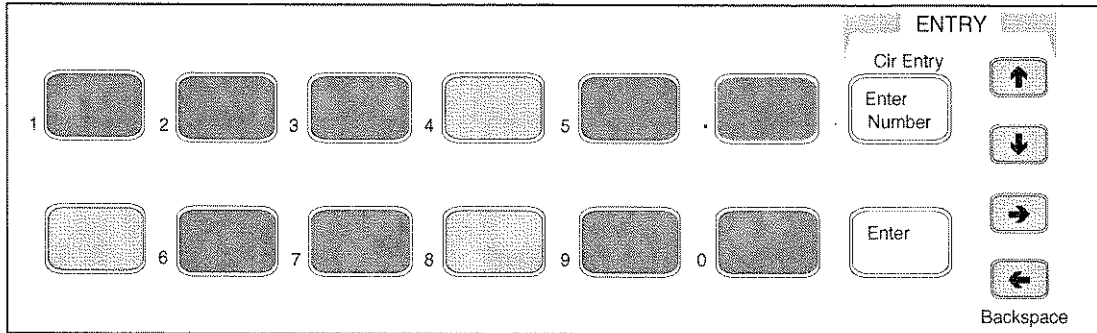

Figure 5-4. Entry Keys



These keys let you scroll through choices in a **parameter** list that apply to a specific command. Parameter lists are circular; you can return to the starting position by continuously pressing either key. If the command has a numeric range, these keys increment or decrement the existing value. In meter mode, these keys can be used to adjust the magnitude of the output voltage or current. Only the flashing digit is changed by these keys. Use the ← and → keys to move the flashing digit.



These keys move the flashing digit in a numeric entry field to the right or left. This lets you increment or decrement a specific digit in the entry field using the ↑ and ↓ keys or the RPG knob.

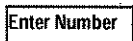

Used only to access a third level key function - the numeric entry keys. These third level function keys are labeled in green.

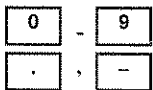

0 through **9** are used for entering numeric values. **.** is the decimal point. **-** is the minus sign. For example, to enter 33.6 press: **Enter Number, 3, 3, ., 6, Enter.**

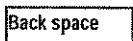

The backspace key deletes the last digit entered from the keypad. This key lets you correct one or more wrong digits before they are entered.



This key aborts a keypad entry by clearing the value. This key is convenient for correcting a wrong value or aborting a value entry. The display then returns to the previously set function.



This key executes the entered value or parameter of the presently accessed command. Until you press this key, the parameters you enter with the other Entry keys are displayed but not entered into the dc source. Before pressing **Enter**, you can change or abort anything previously entered into the display. After **Enter** is pressed, the dc source returns to Meter mode.

Examples of Front Panel Programming

You will find these examples on the following pages:

- 1 Setting the output voltage and current
- 2 Querying and clearing output protection
- 3 Making front panel measurements
- 4 Programming the digital port
- 5 Programming the output relay (option 760 only)
- 6 Setting the GPIB address or RS-232 parameters
- 7 Saving and recalling operating states

Similar examples are given in the dc source Programming Guide using SCPI commands.

1 - Setting the Output Voltage and Current

Set the output voltage

Action	Display
1. To enter an approximate value without using the voltage menu: On the Entry keypad, press ← or → to select the 1's digit in the voltage field. Then rotate the front panel RPG knob to obtain 7 V. <i>If the unit is in CC mode, you won't see the output voltage change until the voltage setting is low enough to cause the unit to go into CV mode.</i>	7.003V 0.004A
2. The easiest way to enter an accurate value: On the Function keypad, press Voltage . On the Entry keypad, press 7 , Enter .	VOLT 7.000
3. To make minor changes to an existing value: On the Function keypad, press Voltage . On the Entry keypad, press ← or → to select the digit in the numeric field that you wish to change. For example, move the flashing digit to the ones column to change a value in this column. Then, press ↑ to scroll from 7.000 to 8.000. Then press Enter .	VOLT 8.000

Set the output current

Action	Display
1. To enter an approximate value without using the current menu: On the Entry keypad, press ← or → to select the tenths digit in the current field. Rotate the front panel RPG knob to obtain 0.4A. <i>If the unit is in CV mode, you won't see the output current change until the current setting is low enough to cause the unit to go into CC mode.</i>	8.003V 0.400A
2. The easiest way to enter an accurate value: On the Function keypad, press Current . On the Entry keypad, press ., 4 , Enter .	CURR 0.400
3. To make minor changes to an existing value: On the Function keypad, press Current . On the Entry keypad, press ← or → to select the digit in the numeric field that you wish to change. For example, move the flashing digit to the tenths column to change a value in this column. Then, press ↑ to scroll from 0.400 to 0.500. Then press Enter .	CURR 0.500

Enable the output

Action	Display
1. On the Function keypad, press Output On/Off to enable the output. The Dis annunciator will go off, indicating that the voltage is now applied to the output terminals. The A display indicates the actual output current.	8.003V 0.500A

2 - Querying and Clearing Output Protection

The dc source will disable its output if it detects an overvoltage or overcurrent fault condition. Other automatic fault conditions (such as overtemperature) also will disable the output.

Query and clear the dc source overcurrent protection feature as follows:

Action	Display
1. On the Function keypad, press Protect . In this example, OC indicates that an overcurrent condition has occurred. Other protection indicators are: OT (overtemperature), OV (overvoltage), RI (remote inhibit), and FS (internal fuse is open).	OC - - - - -
2. On the Function keypad, press Current . This displays the present output current limit. (10% of the maximum rating is the default current limit setting).	CURR 0.2045 (2 amp unit)
3. To restore normal operation <i>after the cause of the overcurrent condition has been removed</i> , press Shift, Prot Clr . The OCP annunciator then will go off.	

3 - Making Front Panel Measurements

When the dc source is operating in front panel meter mode, all front panel measurements are calculated from a total of 2048 readings taken at a 46.8 microsecond sampling rate. The unit alternates between voltage and current measurements. Therefore, the data acquisition time for a single front panel voltage or current measurement is about 100 milliseconds. The sample rate and number of data points are fixed, and there are no trigger controls for front panel measurements. This fixed sampling rate and data acquisition time combined with a built-in windowing function, reduces errors due to sampling a non-integral number of cycles of a waveform for frequencies of 25 Hz or greater. Note that the windowing function is less accurate when measuring output waveforms for frequencies less than 25 Hz, causing the front panel meter to jitter.

When controlling the unit over the GPIB interface, you can vary both the sampling rate and the number of data points in each measurement. If you are using the Agilent 66312A dc source to measure waveform data, the GPIB interface also lets you qualify the triggers that initiate the measurements. With this flexibility, measurement accuracy can be improved for waveforms with frequencies as low as several Hertz. Refer to chapter 3 in the Programming Guide for more information.

Two current measurement ranges can be selected in the Input menu. A high current range is available for measuring output currents up to 30% higher than the maximum rating of the dc source. A low current range is available for improved resolution when measuring output currents below 20 milliamperes. The low current measurement range is accurate to 0.1% of the reading ± 2.5 microamperes. When the current Range is set to AUTO, the unit automatically selects the range that provides the best measurement resolution.

NOTE: If the front panel display indicates OVLD, the output has exceeded the measurement capability of the instrument. If the front panel display indicates - - - - - , an GPIB measurement is in progress.

As previously mentioned, the Agilent 66312A dc source has the capability of measuring output waveform parameters such as peak, minimum, high level, and low level as illustrated in the following figure.

5 - Front Panel Operation

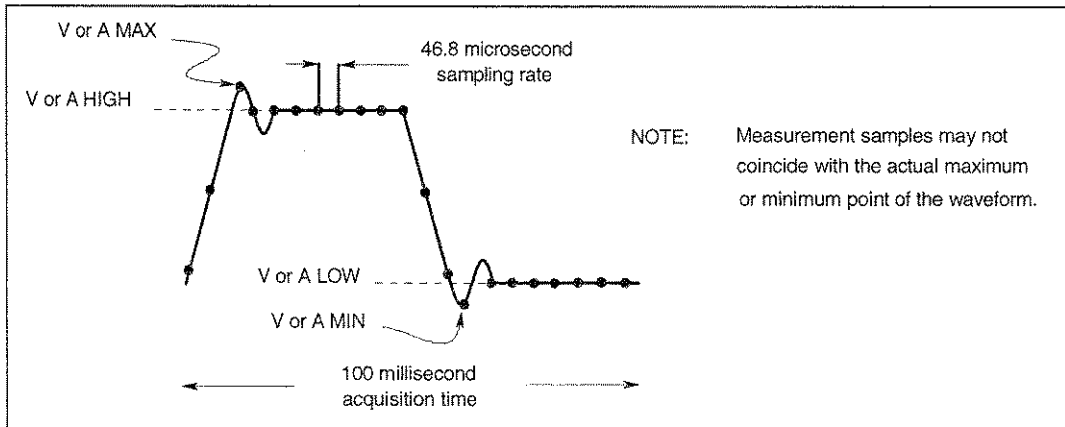

Figure 5-5. Front Panel Pulse Measurement Parameters (Agilent 66312A only)

Use the Meter menu for making front panel measurements:

Action	Display
1. For current measurements, press Shift, Input . Then press \downarrow until you obtain the CURR:RANG AUTO command. Press Enter to activate autoranging. Two other selections are also available. Select the High range when measuring currents above 20 mA. Select the Low range for improved resolution when measuring currents below 20 mA.	CURR:RANG AUTO
2. For output waveform measurements, press Shift, Input . Then press ∇ until you obtain the CURR:DET command. Check to make sure that the ACDC current detector is selected. This provides the best accuracy for waveform measurements. Only select the DC current detector if you are making dc current measurements and you require a dc measurement offset better than 1mA on the High current measurement range.	CURR:DET ACDC

Note: In the Low current measurement range, the current detector is fixed at DC. With the current detector in dc, accurate current measurements cannot be made on waveforms with frequency contents over a few kilohertz.

3. On the Function keypad press Meter and press ∇ repeatedly to access the following measurement parameters:	
◆ dc voltage and current	<reading>V <reading>A
◆ peak voltage ¹	<reading>V MAX
◆ minimum voltage ¹	<reading>V MIN
◆ high level of a voltage pulse waveform ¹	<reading>V HIGH
◆ low level of a voltage pulse waveform ¹	<reading>V LOW
◆ rms voltage ¹	<reading>V RMS
◆ peak current ¹	<reading>A MAX
◆ minimum current ¹	<reading>A MIN
◆ high level of a current pulse waveform ¹	<reading>A HIGH
◆ low level of a current pulse waveform ¹	<reading>A LOW
◆ rms current ¹	<reading>A RMS
¹ Agilent 66312A only	

4 - Programming the Digital Output Port

Your dc source is shipped with the output port function set to RIDFI mode. In this mode the port functions as a remote inhibit input with a discrete fault indicator output signal. You can also configure the port to act as a Digital Input/Output device.

To configure the RIDFI mode of the port, proceed as follows:

Action	Display
1. On the Function keypad, press Output .	*RST
2. Scroll through the Output menu by pressing ▼. The PORT command lets you select either the RIDFI or the DIGIO function.	PORT RIDFI
3. Scroll to the RI command to configure the Remote INHibit indicator. Use the ▲ and ▼ keys to select either LIVE or LATCHING, either of which enable the RI indicator. With RI enabled, a low-true on the INH input will disable the output of the unit. LIVE causes the output of the unit to track the state of the INH input. LATCHING latches the output of the unit off in response to the inhibit signal.	RI LIVE RI LATCHING
4. Access the Output menu again and scroll through the menu. The DFI command lets you enable the Discrete Fault Indicator. Use the ▼ key and select ON to enable the FLT output. With the FLT output enabled, the open-collector logic signal can be used to signal external devices when a fault condition is detected.	DFI ON
5. Scroll to the DFI:SOUR command to select the internal source that drives this signal. Use the ▼ key to select from the RQS or ESB bits, or the Operation or Questionable status registers. Status summary bits are explained in chapter 3 of the Programming Guide.	DFI:SOUR RQS DFI:SOUR ESB DFI:SOUR OPER DFI:SOUR QUES

To configure the DIGIO mode of the port, proceed as follows:

Action	Display
1. On the Function keypad, press Output .	*RST
2. Scroll through the Output menu by pressing ▼. The PORT command lets you select either the RIDFI or the DIGIO function.	PORT DIGIO
3. Scroll to the DIGIO command to set and read the Digital Input/Output Port. Press Enter Number and enter a number from 0 to 7 to program the four bits (0 programs all bits low; 7 programs all bits high). Press Enter when done.	DIGIO 5

5 - Front Panel Operation

5 - Programming the Output Relay (option 760 only)

Units with option 760 have isolation and polarity reversal relays connected to the output and sense terminals. (Option 760 is not available on Agilent 66312A units.)

To control the relays independently of the Output On/Off switch, proceed as follows:

Action	Display
1. On the Function keypad, press Output , and scroll through the Output menu until you get to the RELAY command. The display indicates whether the relay is presently closed (ON), or open (OFF).	RELAY ON
2. Use the ↑ and ↓ keys to select either ON to close the relay or OFF to open the relay. <i>Note that the output relays always open or close whenever the Output On/Off key is pressed.</i>	RELAY OFF

To control the polarity of the output relays, proceed as follows:

Action	Display
1. On the Function keypad, press Output , and scroll through the Output menu until you get to the REL:POL command. The display indicates the present condition of the relay (either normal or reversed).	REL:POL NORM
2. Use the ↑ and ↓ keys to select either NORM or REV. NORMAl causes the relay polarity to be the same as the dc source output REVerse causes the relay polarity to be opposite to that of the dc source output.	RELAY OFF

6 - Setting the GPIB Address and RS-232 Parameters

Your dc source is shipped with the GPIB address set to 5 This address can only be changed from the front panel using the Address menu located under the **Address** key. This menu is also used to select the RS-232 interface and specify RS-232 parameters such baud rate and parity.

Set the GPIB address as follows:

Action	Display
1. On the System keypad, press Address .	ADDRESS 5
2. Enter the new address. For example, Press Enter Number, 7, Enter .	ADDRESS 7

Configure the RS-232 interface as follows:

Action	Display
1. On the System keypad, press Address .	ADDRESS 5
2. Scroll through the Address menu by pressing ▼ . The interface command lets you select the RS-232 interface. The baudrate command lets you select the baudrate. The parity command lets you select the parity. The flow command selects the flow control options.	INTF RS232 BAUDRATE 9600 PARITY EVEN XON-XOFF
3. The ↑ and ↓ keys let you select the command parameters.	

7 - Saving and Recalling Operating States

NOTE: This capability is only available when the unit is set to the SCPI programming language.

You can save up to 4 states (from location 0 to location 3) in non-volatile memory and recall them from the front panel. All programmable settings are saved.

Save an operating state in location 1 as follows:

Action	Display
1. Set the instrument to the operating state that you want to save.	
2. Save this state to location 1. Press Save, Enter Number, 1, Enter .	*SAV 1

Recall a saved state as follows:

Action	Display
1. Recall the state saved in location 1 by pressing Recall, Enter Number, 1, Enter	*RCL 1

Select the power-on state of the dc source as follows:

Action	Display
1. On the Function keypad, press Output , and scroll through the Output menu until you get to the PON state command.	PON:STATE RST
2. Use the ↑ and ↓ keys to select either RST or RCL0. RST sets the power-on state of the unit as defined by the *RST command. RCL0 sets the power-on state of the unit to the state saved in *RCL location 0.	

Clear the non-volatile memory of the dc source as follows:

Action	Display
1. On the Function keypad, press Output, Enter . This returns the unit to the factory-default settings.	*RST
2. Save these settings to location 1. Press Save, Enter Number, 1, Enter .	*SAV 1
3. Repeat step #2 for memory locations 2 through 4..	*SAV 2 *SAV 3 *SAV 4

Specifications

Specifications

Table A-1 lists the specifications of the dc source. Specifications are warranted over the ambient temperature range of 0 to 55 °C. Unless otherwise noted, specifications apply when measured at the rear terminals after a 30-minute warm-up period.

Table A-1. Performance Specifications

Parameter		Agilent 6611C	Agilent 6612C Agilent 66312A	Agilent 6613C	Agilent 6614C
Output Ratings	Voltage: Current:	0 – 8 V 0-5 A	0 – 20 V 0 – 2 A	0 – 50 V 0 – 1 A	0 – 100 V 0 – 0.5 A
Programming Accuracy (@ 25°C ±5°C)	Voltage: 0.05% + +Current: 0.05% +	5 mV 2 mA ¹	10 mV 1 mA ¹	20 mV 0.75 mA ¹	50 mV 0.5 mA ¹
DC Measurement Accuracy (via GPIB or front panel meters with respect to actual output @ 25°C ±5°C)	Voltage: 0.03% + <u>Low Current range</u> –20 mA to +20 mA: 0.1% +	2 mV ² 2.5 µA ³	3 mV ² 2.5 µA ³	6 mV ² 2.5 µA ³	12 mV ² 2.5 µA ³
	<u>High Current range</u> +20 mA to +rated I: 0.2% + –20 mA to – rated I: 0.2% +	0.5mA ⁴ 1.1mA	0.25 mA ⁴ 0.85 mA	0.2 mA ⁴ 0.8 mA	0.1 mA ⁴ 0.7 mA
Ripple and Noise (in the range of 20 Hz to 20 MHz with outputs ungrounded or with either terminal grounded)	Voltage (rms/p-p): Current (rms):	0.5 mV/3 mV 2 mA	0.5 mV/3 mV ⁵ 1 mA	0.5 mV/4 mV 1 mA	0.5 mV/5 mV 1 mA
Load Regulation⁶ (change in output voltage or current for any load change within ratings)	Voltage: Current:	2 mV 1 mA	2 mV 0.5 mA	4 mV 0.5 mA	5 mV 0.5 mA
Line Regulation (change in output voltage or current for any line change within ratings)	Voltage: Current:	0.5 mV 0.5 mA	0.5 mV 0.5 mA	1 mV 0.25 mA	1 mV 0.25 mA
Transient Response Time⁶ (for the output voltage to recover to its previous level within 0.1% of the voltage rating of the unit or 20 millivolts following a change in load current of up to 50% of the output current rating)		< 100 µs			

¹0.05% + 3.32mA (Agilent 6611C), 1.53mA (Agilent 66312A/12C), 1.01mA (Agilent 6613C), 0.063mA (Agilent 6614C) when programming between zero and 0.03% of full scale current.

²Applies for output voltages greater than 10mV (Agilent 6611C/12C), 25mV (Agilent 6613C), and 50mV (Agilent 6614C).

³This specification may degrade slightly when the unit is subjected to an RF field ≥3 V/meter.

⁴For Agilent 66312A: applies in SCPI mode, with current detector set to DC. With current detector set to ACDC, accuracy is 0.2% + four times the fixed error value. In COMPatibility mode, accuracy is 0.2% + six times the fixed error value.

⁵For Agilent 66312A (from 1 MHz to 20 MHz) = 0.5mV/15mV.

⁶Applies at rear terminals with unit set to remote sensing and with sense terminals externally jumpered to their respective output terminals.

Supplemental Characteristics

Table A-2 lists the supplemental characteristics, which are not warranted but are descriptions of typical performance determined either by design or type testing.

Table A-2. Supplemental Characteristics

Parameter		Agilent 6611C	Agilent 6612C Agilent 66312A	Agilent 6613C	Agilent 6614C
Input Rating 47 – 63 Hz (at full load)	100 Vac mains: (87-106 Vac)	2.2 A, 120 W	1.6 A, 100 W	1.6 A, 100 W	1.6 A, 100 W
	115 Vac mains: (104-127 Vac)	2 A, 120 W	1.4 A, 100 W	1.4 A, 100 W	1.4 A, 100 W
	220 Vac mains: (191-233 Vac)	1.1 A, 120 W	0.8A, 100 W	0.8A, 100 W	0.8A, 100 W
	230 Vac mains: (207-253 Vac)	1 A, 120 W	0.75 A, 100 W	0.75 A, 100 W	0.75 A, 100 W
Output Programming Range	Voltage:	0 – 8.190 V	0 – 20.475 V	0 – 51.188 V	0 – 102.38 V
	Current:	0 – 5.118 A	0 – 2.0475 A	0 – 1.0238 A	0 – 0.5118 A
	OVP:	12 V	0 – 22 V	0-55 V	0 – 110 V
Average Programming Resolution	Voltage:	2 mV	5 mV	12.5 mV	25 mV
	Current:	1.25 mA	0.5 mA	0.25 mA	0.125 mA
	OVP:	60 mV	100 mV	250 mV	500 mV
OVP Accuracy	2.4 % +	200 mV ¹	240 mV	600 mV	1.2 V
Maximum Current Measurement		7 A	2.43 A	1.28 A	0.7 A
Average Current Measurement Resolution	High Range:	213 uA	74 uA	39 uA	21 uA
	Low Range:	0.6 uA	0.6 uA	0.6 uA	0.6 uA
Sink Current²		- 3 A	- 1.2 A	- 0.6 A	- 0.3 A
Programming Accuracy Temperature Coefficient (change/C⁰)	Voltage: 0.01% +	0.15 mV	0.25 mV	0.5 mV	1 mV
	Current: 0.01% +	30 uA	12 uA	6 uA	3 uA
	OVP: 0.015% +	2 mV	4 mV	10 mV	20 mV
Readback Accuracy Temperature Coefficient (change/C⁰)	Voltage: 0.01% +	60 uV	150 uV	500 uV	700 uV
	Current (DC): 0.02% +	25 uA	10 uA	5 uA	3 uA
	Current (ACDC): 0.05% +	160 uA	80 uA	40 uA	20 uA
	Current (Low Range): 0.01% +	0.3 uA	0.3 uA	0.3 uA	0.3 uA
Drift³	Voltage: 0.01% +	0.25 mV	0.5 mV	1 mV	1 mV
	Current: 0.01% +	50 uA	20 uA	10 uA	10 uA
Output Voltage Rise/Fall Time (for a change from 10% to 90% or 90% to 10% of the total excursion)		2 ms			
Output Voltage Settling Time (to settle within 1 LSB or 0.025% times the rated voltage of the final value)		6 ms			

¹ Agilent 6611C Option 760 = 2.4% + 500mV.

² The sink current does not track the programmed current.

³ Following a 30 minute warm-up, the change in output over 8 hours, under constant ambient, load and line operating conditions.

Table A-2. Supplemental Characteristics (continued)

Parameter		Agilent 66312A	Agilent 6611C - 6614C
Dynamic Measurement Accuracy	Instantaneous Voltage: Instantaneous Current:	0.03% + 5 mV 0.6% + 1 mA ¹	not applicable
Dynamic Measurement System	Buffer Length: Sampling Rate Range:	4096 points 15.6µs–31,200s	not applicable
Measurement Time (voltage or current)		50 ms average (includes the default time of 30 ms ² for acquiring data, and a 20 ms data processing overhead)	
Command Processing Time		4 ms average (for output to begin to change following receipt of digital data)	
Remote Sense Capability		Up to 2 V can be dropped across each load lead. (add 2 mV to the voltage load regulation specification for each 1 V change in the positive output lead due to load current change.)	
Savable Instrument States (applies only in SCPI mode)		4 (in locations 0 to 3)	
RS-232 Interface Capabilities	Baud rates: Data formats: Language:	300 600 1200 2400 4800 9600 7 bits even or odd parity; 8 bits without parity SCPI or COMPatibility ³	
 GPIB Interface Capabilities	Language: Interface:	SCPI or COMPatibility ³ AH1, C0, DC1, DT1, E1, L4, PP0, RL1, SH1, SR1, T6	
INH/FLT Characteristics	Maximum ratings: FLT Terminals: INH Terminals:	16.5 Vdc between terminals 1 and 2; 3 and 4; and from terminals 1 or 2 to chassis ground Low-level output current = 1.25 mA max. Low-level output voltage = 0.5 V max. Low-level input voltage = 0.8 V max. High-level input voltage = 2 V min. Low-level input current = 1 mA Pulse width = 100 µs min. Time delay = 4 ms typical	
Digital I/O Characteristics	Maximum ratings: Digital OUT Port 0,1,2 (open collector)	same as INH/FLT Characteristics Output leakage @ 16V = 0.1 mA (ports 0,1) = 12.5 mA (port 2) Output leakage @ 5V = 0.1 mA (ports 0,1) = 0.25 mA (port 2) Low-level output sink current @ 0.5 V = 4 mA Low-level output sink current @ 1 V = 50 mA	

¹For full scale current changes with a risetime of 20 µs, an additional 0.5% error exists in the first data point in the buffer after the change. The error percentage increases proportionally with the decrease in risetime.

²This time may be reduced by changing the default conditions of 2048 data points, however, measurement accuracy will be reduced.

³COMPatibility language is used to program the Agilent 663xA Series power supplies.

A - Specifications

Table A-2. Supplemental Characteristics (continued)

Parameter		Agilent 66312A	Agilent 6611C - 6614C
Digital I/O Characteristics (continued)	Digital IN Port 2: (internal pull-up)	Low-level input current @ 0.4 V = 1.25 mA High-level input current @ 5 V = 0.25 mA Low-level input voltage = 0.8 V max. High level input voltage = 2.0 V min.	
Isolation to Ground (Maximum from either output terminal to chassis)		50 Vdc	240 Vdc
Recommended Calibration Interval		1 year (from the date the unit is put into service)	
Regulatory Compliance	Listing pending: Certified to: Conforms to: Complies with:	UL 3111-1 CSA 22.2 No. 1010.1 IEC 1010-1 EMC directive 89/336/EEC (ISM Group1 Class B)	
Dimensions (see figure 3-1)	Height: Width: Depth:	88.1 mm (3.5in.) 212.8 mm (8.4in.) 444.4 mm (17.5 in.)	88.1 mm (3.5in.) 212.8 mm (8.4in.) 368.3 mm (14.5 in.)
Net weight		8.8 kg (19.5 lbs.)	8.2 kg (18.16 lbs.)
Shipping weight		11.1 kg (24.5 lbs.)	10.6 kg (23.5 lbs.)

Verification and Calibration

Introduction

This appendix includes verification and calibration procedures for the Agilent 66312A, 6611C, 6612C, 6613C and 6614C dc source. Instructions are given for performing the procedures either from the front panel or from a controller over the GPIB.

The verification procedures do not check all the operating parameters, but verify that the dc source is performing properly. Performance Tests, which check all the specifications of the dc source, are given in the applicable dc source Service Manual.

Important Perform the verification procedures before calibrating your dc source. If the dc source passes the verification procedures, the unit is operating within its calibration limits and does not need to be recalibrated.

Equipment Required

The equipment listed in the following table, or the equivalent to this equipment, is required for verification and calibration.

Table B-1. Equipment Required

Equipment	Characteristics	Recommended Model
Digital Voltmeter	Resolution: 10 nV @ 1 V Readout: 8.5 digits Accuracy: >20 ppm	Agilent 3458A
Current Monitor ¹	15 A (0.1 Ω), $\pm 0.04\%$, TC=5ppm/ $^{\circ}$ C	Guildline 9230/15
Load Resistor (3 W min. TC=20ppm/ $^{\circ}$ C)	400 Ω (Agilent 6611C calibration and all models verification.) 1.1 k Ω (Agilent 6612C & 66312A calibration) 2500 Ω (Agilent 6613C calibration) 5000 Ω (Agilent 6614C calibration)	p/n 0811-2878
Power Supply	8 V @ 5 A	Agilent 6611C or Agilent 6631B
GPIB Controller	Full GPIB capabilities	HP Series 200/300 or equivalent

¹The 4-terminal current shunt is used to eliminate output current measurement error caused by voltage drops in the load leads and connections. It has special current-monitoring terminals inside the load connection terminals. Connect the voltmeter directly to these current-monitoring terminals.

Test Setup

Figure B-1 shows the setup for the tests. Be certain to use load leads of sufficient wire gauge to carry the full output current (see chapter 3).

B - Verification and Calibration

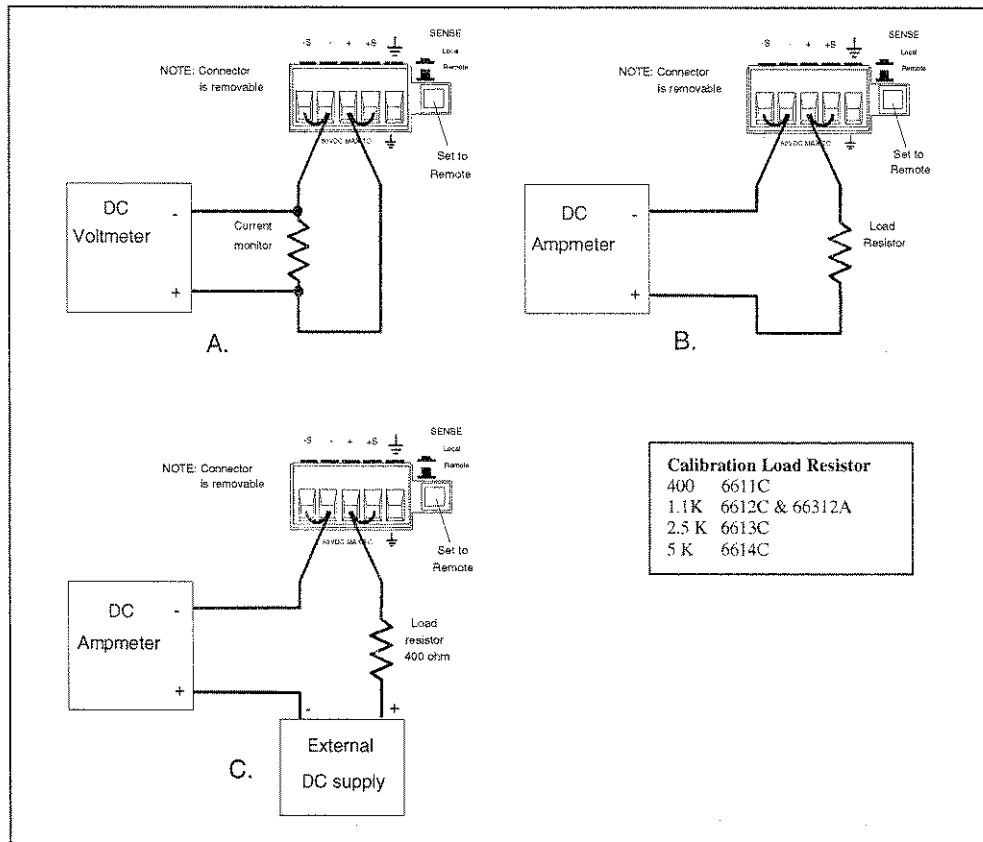

Figure B-1. Verification & Calibration Test Setup

Performing the Verification Tests

NOTE: The verification procedure can only be performed using the SCPI language commands. Use either the front panel **Address** key to access the LANG command, or use the **SYSTEM:LANGUage** command to change the programming language to SCPI.

The following procedures assume you understand how to operate the dc source from the front panel as explained in chapter 5.

When performing the verification tests from an GPIB controller, you may have to consider the relatively slow settling times and slew rates of the dc source as compared to computer and system voltmeters. Suitable WAIT statements can be inserted into the test program to give the dc source time to respond to the test commands.

Perform the following tests for operation verification in the order indicated.

1. Turn-On Checkout
2. Voltage Programming and Measurement Accuracy
3. Current Programming and Measurement Accuracy

Table B-2. Verification Programming Values

	Full scale Voltage	Full Scale Current	I _{max}	I _{sink}
6611C	8	5	5.1188	- 3 A
6612C/66312A	20	2	2.0475	- 1.2 A
6613C	50	1	1.0238	- 0.6 A
6614C	100	0.5	0.5118	- 0.3 A

Turn-On Checkout

Perform the Turn-On Checkout as directed in chapter 4.

NOTE: The dc source must pass turn-on selftest before you can proceed with the verification tests.

Voltage Programming and Measurement Accuracy

This test verifies the voltage programming, GPIB measurement, and front panel meter functions. Values read back over the GPIB should be the same as those displayed on the front panel. Measure the dc output voltage at the output terminals. Make sure the sense switch is set to remote and the sense terminals are directly jumpered to the output terminals.

Action	Normal Result
1. Turn off the dc source and connect a DMM to the output terminals.	
2. Turn on the dc source with no load on the output. Set the output voltage to 0 V and the output current to full scale (see table B-2). Press Output On/Off to enable the output.	Output voltage near 0 V. Output current near 0 A.
3. Record voltage readings at the DMM and on the front panel display.	Readings within low voltage limits (see table B-3, 4, 5 or 6).
4. Set the output voltage to the full scale rated voltage (see table B-2).	Output voltage near full scale.
5. Record voltage readings at the DMM and on the front panel display.	Readings within high voltage limits (see table B-3, 4, 5 or 6).

Current Programming and Measurement Accuracy

This test verifies the current programming and measurement. Connect the appropriate current monitor (see table B-1) as shown in figure B-1A.

Current Programming and Measurement (High Range)

Action	Normal Result
1. Turn off the dc source and connect the DMM and current monitor as shown in figure B-1A.	
2. Turn on the dc source, access the Input menu, and set the current sense detector to DC.	CURR:DET DC
3. Set the output voltage to 5 V and the current to 0 A. Press Output On/Off to enable the output.	Output current near 0 A.
4. Divide the voltage drop across the current monitor by its resistance	Readings within low current

B - Verification and Calibration

- to convert the value to amperes. Record the value. limits (see table B-3, 4, 5 or 6).
5. Set the output current to full scale (see table B-2)..
 6. Divide the voltage drop across the current monitor by its resistance to convert the value to amperes. Record this value and the current reading on the front panel display. Readings within high current limits (see table B-3, 4, 5 or 6).

Current Measurement (Low Range)

Action	Normal Result
7. Turn off and connect the dc source as shown in Figure B-1B using the 400 ohm load resistor. Set the DMM to operate in current mode.	
8. Turn on the dc source, access the Input menu, and set the current range to LOW.	CURR:RANG LOW
9. Set the output voltage to 0 V and the current to full scale (see table B-2). Press Output On/Off to enable the output.	Output current near 0 A.
10. Record the current reading from the DMM as well as from the front panel display. Enter the difference between the two readings in the appropriate table.	Readings within low current measurement (see table B-3, 4, 5 or 6).
11. Set the output voltage to 8 V.	Output current near +20 mA.
12. Record the current reading from the DMM as well as from the front panel display. Enter the difference between the two readings in the table.	Readings within high current measurement (see table B-3, 4, 5 or 6).

Current Sink Measurement

Action	Normal Result
13. Turn off the dc source and connect an external supply to the output of the unit as shown in figure B-1C using the 400 ohm load resistor. Set the DMM to operate in current mode.	
14. Turn on the dc source, access the Input menu, and set the current range to LOW.	CURR:RANG LOW
15. Access the Input menu and set the current sense detector to DC.	CURR:DET DC
16. Turn on the external supply and program it to 8 volts and 5 A. Program the dc source to 0 V and 1 A. Press Output On/Off to enable the output.	Output current near -20 mA.
17. Record the current reading from the DMM as well as from the front panel display. Enter the difference between the two readings in the table.	Readings within low current sink measurement (see table B-3, 4, 5 or 6).
18. Access the Input menu and set the current range to HIGH.	CURR:RANG HIGH
19. Short out the load resistor by connecting a jumper across it.	Output current near -Isink (see table B-2)
20. Record the current reading from the DMM as well as from the front panel display. Enter the difference between the two readings in the table.	Readings within high current sink measurement (see table B-3, 4, 5 or 6).

Table B-3. Verification Test Record for Agilent 6611C

Model Agilent 6611C		Report No. _____	Date _____
Test Description	Minimum Specification	Recorded Results	Maximum Specification
Voltage Programming and Measurement			
Low Voltage V_{out}	-5 mV	_____ V	+5 mV
Front Panel measurement	V_{out} -2 mV	_____ mV	V_{out} +2 mV
High Voltage V_{out}	7.991 V	_____ V	8.009 V
Front Panel measurement	V_{out} -4.4 mV	_____ mV	V_{out} +4.4 mV
Current Programming and Measurement (High Range)			
Low Current I_{out}	-2 mA	_____ A	2 mA
High Current I_{out}	4.9955 A	_____ A	5.0045 A
Front Panel measurement	I_{out} -10.5 mA	_____ mA	I_{out} +10.5 mA
Current Measurement (Low Range)			
Low Current measurement	I_{out} -2.5 μ A	_____ μ A	I_{out} +2.5 μ A
High Current measurement	I_{out} -22.5 μ A	_____ μ A	I_{out} +22.5 μ A
Current Sink Measurement			
Low Current Sink measurement	I_{sink} -22.5 μ A	_____ μ A	I_{sink} +22.5 μ A
High Current Sink measurement	I_{sink} -11.1 mA	_____ mA	I_{sink} +11.1 mA

Table B-4. Verification Test Record for Agilent 66312A or Agilent 6612C

Model Agilent		Report No. _____	Date _____
Test Description	Minimum Specification	Recorded Results	Maximum Specification
Voltage Programming and Measurement			
Low Voltage V_{out}	-10 mV	_____ V	+10 mV
Front Panel measurement	V_{out} -3 mV	_____ mV	V_{out} +3 mV
High Voltage V_{out}	19.980 V	_____ V	20.020 V
Front Panel measurement	V_{out} -9 mV	_____ mV	V_{out} +9 mV
Current Programming and Measurement (High Range)			
Low Current I_{out}	-1 mA	_____ A	1 mA
High Current I_{out}	1.998 A	_____ A	2.002 A
Front Panel measurement	I_{out} -4.5 mA	_____ mA	I_{out} +4.5 mA
Current Measurement (Low Range)			
Low Current measurement	I_{out} -2.5 μ A	_____ μ A	I_{out} +2.5 μ A
High Current measurement	I_{out} -22.5 μ A	_____ μ A	I_{out} +22.5 μ A
Current Sink Measurement			
Low Current Sink measurement	I_{sink} -22.5 μ A	_____ μ A	I_{sink} +22.5 μ A
High Current Sink measurement	I_{sink} -4.85 mA	_____ mA	I_{sink} +4.85 mA

B - Verification and Calibration

Table B-5. Verification Test Record for Agilent 6613C

Model Agilent 6613C		Report No. _____	Date _____
Test Description	Minimum Specification	Recorded Results	Maximum Specification
Voltage Programming and Measurement			
Low Voltage V_{out}	-20 mV	_____ V	+20 mV
Front Panel measurement	V_{out} -6 mV	_____ mV	V_{out} +6 mV
High Voltage V_{out}	49.955 V	_____ V	20.045 V
Front Panel measurement	V_{out} -21 mV	_____ mV	V_{out} +21 mV
Current Programming and Measurement (High Range)			
Low Current I_{out}	-0.5 mA	_____ A	0.5 mA
High Current I_{out}	0.999 A	_____ A	1.001 A
Front Panel measurement	I_{out} -2.2 mA	_____ mA	I_{out} +2.2 mA
Current Measurement (Low Range)			
Low Current measurement	I_{out} -2.5 μ A	_____ μ A	I_{out} +2.5 μ A
High Current measurement	I_{out} -22.5 μ A	_____ μ A	I_{out} +22.5 μ A
Current Sink Measurement			
Low Current Sink measurement	I_{sink} -22.5 μ A	_____ μ A	I_{sink} +22.5 μ A
High Current Sink measurement	I_{sink} -2.8 mA	_____ mA	I_{sink} +2.8 mA

Table B-6. Verification Test Record for Agilent 6614C

Model Agilent 6614C		Report No. _____	Date _____
Test Description	Minimum Specification	Recorded Results	Maximum Specification
Voltage Programming and Measurement			
Low Voltage V_{out}	-50 mV	_____ V	+50 mV
Front Panel measurement	V_{out} -12 mV	_____ mV	V_{out} +12 mV
High Voltage V_{out}	99.900 V	_____ V	100.100 V
Front Panel measurement	V_{out} -42 mV	_____ mV	V_{out} +42 mV
Current Programming and Measurement (High Range)			
Low Current I_{out}	-0.25 mA	_____ A	0.25 mA
High Current I_{out}	0.4995 A	_____ A	0.5005 A
Front Panel measurement	I_{out} -1.1 mA	_____ mA	I_{out} +1.1 mA
Current Measurement (Low Range)			
Low Current measurement	I_{out} -2.5 μ A	_____ μ A	I_{out} +2.5 μ A
High Current measurement	I_{out} -22.5 μ A	_____ μ A	I_{out} +22.5 μ A
Current Sink Measurement			
Low Current Sink measurement	I_{sink} -22.5 μ A	_____ μ A	I_{sink} +22.5 μ A
High Current Sink measurement	I_{sink} -1.7 mA	_____ mA	I_{sink} +1.7 mA

Performing the Calibration Procedure

NOTE: The calibration procedure can only be performed using the SCPI language commands. Use either the front panel **Address** key to access the LANG command, or use the SYSTem:LANGUage command to change the programming language to SCPI.

Table B-1 lists the equipment required for calibration. Figure B-1 shows the test setup.

You do not have to do a complete calibration each time. If appropriate, you may calibrate only the voltage or current and proceed to "Saving the Calibration Constants". However, the voltage or current calibration sequence must be performed in its entirety. The following parameters may be calibrated:

- ◆ voltage programming and measurement
- ◆ overvoltage protection (OVP)
- ◆ current programming and measurement
- ◆ low range measurement
- ◆ ac current measurement

Front Panel Calibration Menu



The Entry keypad is used for calibration functions.



Shift	Cal	Press this key to access the calibration menu.																								
		<table border="0" style="width: 100%;"> <thead> <tr> <th style="text-align: left;">Display</th> <th style="text-align: left;">Command Function</th> </tr> </thead> <tbody> <tr> <td>CAL ON <value></td> <td>Turns calibration mode on when the correct password value is entered.</td> </tr> <tr> <td>CAL OFF</td> <td>Turns calibration mode off</td> </tr> <tr> <td>CAL:LEV <char></td> <td>Advance to next step in sequence (P1 or P2).</td> </tr> <tr> <td>CAL:DATA <value></td> <td>Enter an external calibration measurement.</td> </tr> <tr> <td>CAL:VOLT</td> <td>Begin voltage calibration sequence</td> </tr> <tr> <td>CAL:VOLT:PROT</td> <td>Begin voltage protection calibration</td> </tr> <tr> <td>CAL:CURR</td> <td>Begin high range current calibration sequence</td> </tr> <tr> <td>CAL:CURR:MEAS:LOW</td> <td>Begin low range current measurement calibration</td> </tr> <tr> <td>CAL:CURR:MEAS:AC</td> <td>Begin ac current calibration sequence</td> </tr> <tr> <td>CAL:SAVE</td> <td>Saves the calibration constants in non-volatile memory.</td> </tr> <tr> <td>CAL:PASS <value></td> <td>Set new calibration password.</td> </tr> </tbody> </table>	Display	Command Function	CAL ON <value>	Turns calibration mode on when the correct password value is entered.	CAL OFF	Turns calibration mode off	CAL:LEV <char>	Advance to next step in sequence (P1 or P2).	CAL:DATA <value>	Enter an external calibration measurement.	CAL:VOLT	Begin voltage calibration sequence	CAL:VOLT:PROT	Begin voltage protection calibration	CAL:CURR	Begin high range current calibration sequence	CAL:CURR:MEAS:LOW	Begin low range current measurement calibration	CAL:CURR:MEAS:AC	Begin ac current calibration sequence	CAL:SAVE	Saves the calibration constants in non-volatile memory.	CAL:PASS <value>	Set new calibration password.
Display	Command Function																									
CAL ON <value>	Turns calibration mode on when the correct password value is entered.																									
CAL OFF	Turns calibration mode off																									
CAL:LEV <char>	Advance to next step in sequence (P1 or P2).																									
CAL:DATA <value>	Enter an external calibration measurement.																									
CAL:VOLT	Begin voltage calibration sequence																									
CAL:VOLT:PROT	Begin voltage protection calibration																									
CAL:CURR	Begin high range current calibration sequence																									
CAL:CURR:MEAS:LOW	Begin low range current measurement calibration																									
CAL:CURR:MEAS:AC	Begin ac current calibration sequence																									
CAL:SAVE	Saves the calibration constants in non-volatile memory.																									
CAL:PASS <value>	Set new calibration password.																									



Notes:

value = a numeric value

char = a character string parameter

Use  and  to scroll through the menu commands.

Use  and  to scroll through the menu parameters.

Use  and  to select a digit in a numeric entry field.

Front Panel Calibration

B - Verification and Calibration

These procedures assume you understand how to operate front panel keys (see chapter 5).

Enable Calibration Mode

Action	Display
1. Reset the unit by selecting Output , scrolling to *RST and pressing Enter .	*RST
2. Press Output On/Off to enable the output.	00.003V 0.0006A
3. To begin calibration press Shift Cal , scroll to CAL ON and press Enter .	CAL ON 0.0
4. Enter the calibration password from Entry keypad and press Enter . If the password is correct the Cal annunciator will come on. If CAL DENIED appears, then an internal switch has been set to prevent the calibration from being changed. (See the Service Manual.) If the password is incorrect, an error occurs. If the active password is lost, the calibration function can be recovered by setting an internal switch that defeats password protection. (See the Service Manual.)	CAL DENIED OUT OF RANGE

Voltage Programming and Measurement Calibration

Action	Display
5. Connect the DMM (dc volts mode) directly to the dc source. Do not connect the load resistor or current shunt.	
6. Press Shift Cal , scroll to CAL VOLT, and press Enter .	CAL:VOLT
7. Press Shift Cal , scroll to CAL LEV, and press Enter to select the first calibration point.	CAL:LEV P1
8. Press Shift Cal , scroll to CAL DATA, press Enter Number , and enter the voltage value displayed on the DMM.	CAL:DATA 0.00
9. Press Shift Cal , scroll to CAL LEV, use \downarrow to scroll to P2 (the second calibration point), and press Enter .	CAL:LEV P2
10. Press Shift Cal , scroll to CAL DATA, press Enter Number , and enter the second voltage value displayed on the DMM.	CAL:DATA 0.00

Overvoltage Protection Calibration

Action	Display
11. Press Shift Cal , scroll to CAL VOLT PROT, and press Enter .	CAL:VOLT:PROT
12. Wait for the dc source to compute the OVP calibration constant. The display returns to Meter mode when the calculation is complete.	

Current Programming and High-Range Measurement Calibration

Action	Display
13. Connect the appropriate current monitor as shown in figure B-1A. Connect the DMM (in dc mode) across the current shunt.	
14. Press Shift Cal , scroll to CAL CURR, and press Enter .	CAL:CURR
15. Press Shift Cal , scroll to CAL LEV, and press Enter to select the first calibration point.	CAL:LEV P1
16. Press Shift Cal and scroll to CAL DATA. Wait for the DMM reading to stabilize. Then read the DMM and compute the first current value (DMM reading ÷ shunt resistance). Press Enter Number and enter the first current value.	CAL:DATA 0.00
17. Press Shift Cal , scroll to CAL LEV, use ↓ to scroll to P2 (the second calibration point), and press Enter .	CAL:LEV P2
18. Press Shift Cal and scroll to CAL DATA. Wait for the DMM reading to stabilize. Then read the DMM and compute the second current value (DMM reading ÷ shunt resistance). Press Enter Number and enter the second current value.	CAL:DATA 0.00

Low-Range Current Measurement Calibration

Action	Display
19. Press Shift Cal , scroll to CAL CURR MEAS LOW, and press Enter .	CAL:CURR:MEAS:LOW
20. Connect the appropriate calibration load resistor as shown in figure B-1B. Connect the DMM (in current mode) in series with the load.	
21. Press Shift Cal , scroll to CAL LEV, and press Enter to select the first calibration point.	CAL:LEV P1
22. Press Shift Cal and scroll to CAL DATA. Wait for the DMM reading to stabilize. Then press Enter Number and enter the current reading displayed on the DMM.	CAL:DATA 0.00

AC Current Measurement Calibration (Agilent 66312A only)

Action	Display
23. Disconnect all loads from the dc source.	
24. Press Shift Cal , scroll to CAL CURR MEAS AC, and press Enter .	CAL:CURR:MEAS AC
25. Wait for the dc source to compute the ac current calibration constant. The display returns to Meter mode when the calculation is complete.	

B - Verification and Calibration

Saving the Calibration Constants

WARNING: Storing calibration constants overwrites the existing ones in non-volatile memory. If you are not sure you want to permanently store the new constants, omit this step. The dc source calibration will then remain unchanged.

	Action	Display
26.	Press Shift Cal , scroll to CAL SAVE, and press Enter .	CAL:SAVE
27.	Press Shift Cal , select CAL OFF, and press Enter to exit Calibration mode. *RST and *RCL will also set the calibration state to OFF.	CAL OFF

Calibration Error Messages

Errors that can occur during calibration are shown in the following table.

Table B-6. GPIB Calibration Error Messages

Error	Meaning
401	CAL switch prevents calibration (This is a hardware disable, see the Service Manual.)
402	CAL password is incorrect
403	CAL not enabled
404	Computed readback cal constants are incorrect
405	Computed programming cal constants are incorrect
406	Incorrect sequence of calibration commands

Changing the Calibration Password

The factory default password is 0. You can change the password when the dc source is in calibration mode (which requires you to enter the existing password). Proceed as follows:

	Action	Display
1.	Begin by pressing Shift Cal and scrolling to the CAL ON command.	CAL ON 0.0
2.	Enter the existing password from Entry keypad and press Enter	
3.	Press Shift Cal and scroll to the CAL PASS command.	CAL:PASS 0
4.	Enter the new password from the keypad. You can use any number with up to six digits and an optional decimal point. If you want the calibration function to operate without requiring any password, change the password to 0 (zero).	

NOTE: If you want the calibration function to operate without requiring any password, change the password to 0 (zero).

Calibration Over the GPIB

You can calibrate the dc source by using SCPI commands within your controller programming statements. Be sure you are familiar with calibration from the front panel before you calibrate from a controller. Each front panel calibration command has a corresponding SCPI command. When you write your calibration program, perform the calibration procedure in the same order as the front panel procedure documented in this appendix.

The SCPI calibration commands are explained in chapter 3 of the dc source Programming Guide. Calibration error messages that can occur during GPIB calibration are shown in table B-3.

Error Messages

Error Number List

This appendix gives the error numbers and descriptions that are returned by the dc source. Error numbers are returned in two ways:

- ◆ Error numbers are displayed on the front panel
- ◆ Error numbers and messages are read back with the `SYSTEM:ERRor?` query. `SYSTEM:ERRor?` returns the error number into a variable and returns two parameters: an NR1 and a string.

The following table lists the errors that are associated with SCPI syntax errors and interface problems. It also lists the device dependent errors. Information inside the brackets is not part of the standard error message, but is included for clarification.

When errors occur, the Standard Event Status register records them in bit 2, 3, 4, or 5 as described in the following table:

Table C-1. Error Numbers

Error Number	Error String [Description/Explanation/Examples]
Command Errors –100 through –199 (sets Standard Event Status Register bit #5)	
–100	Command error [generic]
–101	Invalid character
–102	Syntax error [unrecognized command or data type]
–103	Invalid separator
–104	Data type error [e.g., "numeric or string expected, got block data"]
–105	GET not allowed
–108	Parameter not allowed [too many parameters]
–109	Missing parameter [too few parameters]
–112	Program mnemonic too long [maximum 12 characters]
–113	Undefined header [operation not allowed for this device]
–121	Invalid character in number [includes "9" in octal data, etc.]
–123	Numeric overflow [exponent too large; exponent magnitude >32 k]
–124	Too many digits [number too long; more than 255 digits received]
–128	Numeric data not allowed
–131	Invalid suffix [unrecognized units, or units not appropriate]

C - Error Messages

-138	Suffix not allowed
-141	Invalid character data [bad character, or unrecognized]
-144	Character data too long
-148	Character data not allowed
-150	String data error
-151	Invalid string data [e.g., END received before close quote]
-158	String data not allowed
-160	Block data error
-161	Invalid block data [e.g., END received before length satisfied]
-168	Block data not allowed
-170	Expression error
-171	Invalid expression
-178	Expression data not allowed
Execution Errors –200 through –299 (sets Standard Event Status Register bit #4)	
-200	Execution error [generic]
-222	Data out of range [e.g., too large for this device]
-223	Too much data [out of memory; block, string, or expression too long]
-224	Illegal parameter value [device-specific]
-225	Out of memory
-270	Macro error
-272	Macro execution error
-273	Illegal macro label
-276	Macro recursion error
-277	Macro redefinition not allowed
System Errors –300 through –399 (sets Standard Event Status Register bit #3)	
-310	System error [generic]
-350	Too many errors [errors beyond 9 lost due to queue overflow]
Query Errors –400 through –499 (sets Standard Event Status Register bit #2)	
-400	Query error [generic]
-410	Query INTERRUPTED [query followed by DAB or GET before response complete]
-420	Query UNTERMINATED [addressed to talk, incomplete programming message received]
-430	Query DEADLOCKED [too many queries in command string]
-440	Query UNTERMINATED [after indefinite response]

Selftest Errors 0 through 99 (sets Standard Event Status Register bit #3)	
0	No error
1	Non-volatile RAM RD0 section checksum failed
2	Non-volatile RAM CONFIG section checksum failed
3	Non-volatile RAM CAL section checksum failed
4	Non-volatile RAM STATE section checksum failed
5	Non-volatile RST section checksum failed
10	RAM selftest
11	VDAC/IDAC selftest 1
12	VDAC/IDAC selftest 2
13	VDAC/IDAC selftest 3
14	VDAC/IDAC selftest 4
15	OVDAC selftest
80	Digital I/O selftest error
Device-Dependent Errors 100 through 32767 (sets Standard Event Status Register bit #3)	
213	Ingrd receiver buffer overrun
216	RS-232 receiver framing error
217	RS-232 receiver parity error
218	RS-232 receiver overrun error
220	Front panel uart overrun
221	Front panel uart framing
222	Front panel uart parity
223	Front panel buffer overrun
224	Front panel timeout
401	CAL switch prevents calibration
402	CAL password is incorrect
403	CAL not enabled
404	Computed readback cal constants are incorrect
405	Computed programming cal constants are incorrect
406	Incorrect sequence of calibration commands
407	CV or CC status is incorrect for this command
408	Output mode switch must be in NORMAL position
601	Too many sweep points
602	Command only applies to RS-232 interface
603	CURRENT or VOLTAGE fetch incompatible with last acquisition
604	Measurement overrange

Line Voltage Conversion

WARNING: *Shock Hazard* Operating personnel must not remove instrument covers. Component replacement and internal adjustments must be made only by qualified service personnel.

Open the Unit

- ◆ Turn off ac power and disconnect the power cord from the unit.
- ◆ Loosen the two screws on the rear bezel and remove the bezel (use a #15 Torx drive).
- ◆ Remove the two screws on the bottom of the unit (use a #15 Torx drive).
- ◆ Pull the cover back to remove it from the unit.

Configure the Power Transformer

- ◆ Locate the ac input wiring harness on the left side of the transformer
- ◆ Use a needlenose pliers and connect the ac input wiring harness according to the information in the following figure:

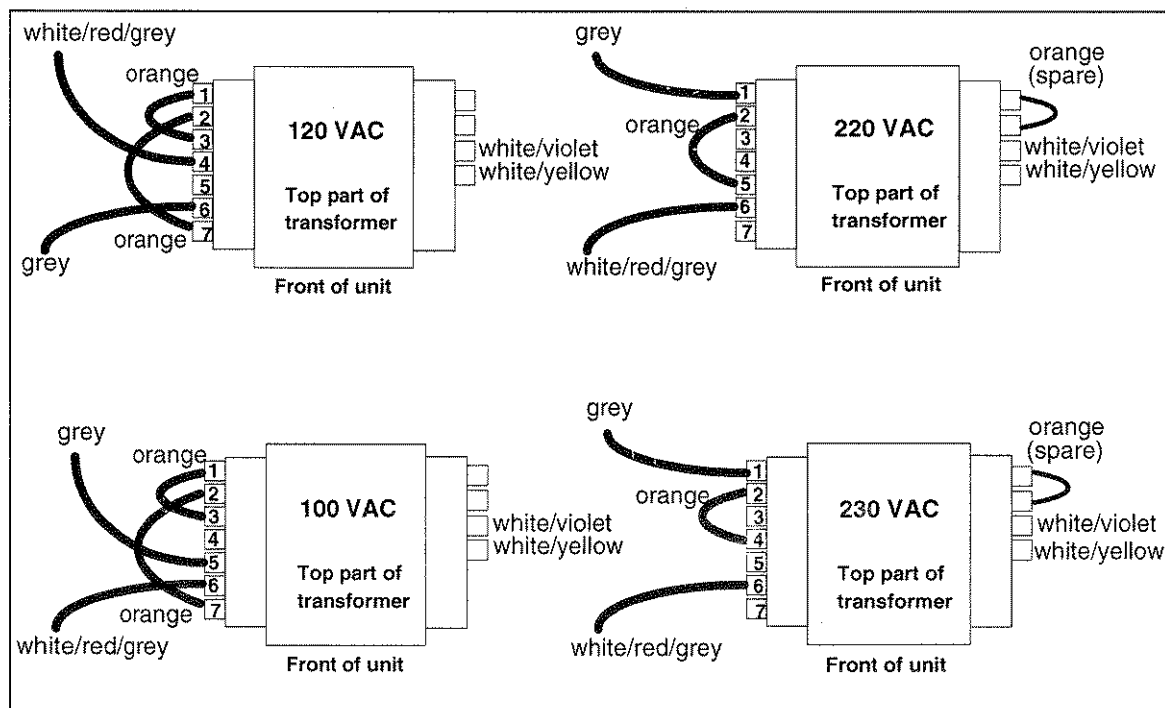

Figure D-1, Power Transformer AC Input Connections

D - Line Voltage Conversion

Install the Correct Line Fuse

- ◆ Unscrew the line fuse cap from the rear panel and install the correct fuse.
For 100/120 Vac operation: 2.5 AT (time delay); part number 2110-0633
For 220/230 Vac operation: 1.25 AT (time delay); part number 2110-0788
- ◆ Mark the voltage setting that the unit has been set to on the rear panel label.

Close the Unit

- ◆ Replace the outer cover.
- ◆ Reconnect the power cord and turn on the unit.

Index

-----, 43

+/- terminals, 23
+S/-S terminals, 23

0 ... 9, 41

ac line conversion, 69
accessories, 18
ACDC current detector, 44
airflow, 22
annunciators
 Addr, 36
 Cal, 36
 CC, 36
 CV, 36
 Dis, 36
 Err, 36
 OCP, 36
 Prot, 36
 Rmt, 36
 Shift, 36
 SRQ, 36
 Unr, 36
AWG ratings, 23

cables, 18
calibration, 59
 current programming - high range, 61
 current programming - low range, 61
 enable, 60
 equipment, 53
 error messages, 62
 menu, 59
 OVP, 60
 password, 62
 peak current, 61
 saving, 62
 setup, 53
 voltage measurement, 60
 voltage programming, 60
capacitor discharge limit, 26
CC mode, 42

checkout procedure, 32
cleaning, 21
clear protection, 43
controller connections, 28
controls and indicators, 19
conversion, ac line, 69
crowbar circuit, 26
current measurement range, 43
CV mode, 20, 42

damage, 21
DC current detector, 44
DFI signal, 26
DIGIO, 45
digital connector, 21, 26
digital I/O, 26
digital output port, 45
dimensions, 22
disabling multiple units, 27

enable output, 42
enter value, 42
entry keys, 41
 ←, 41
 0 ... 9, 41
 Backspace, 41
 Clear Entry, 41
 Enter Number, 41
error messages, 34
error numbers, 65

features, 19
FLT, 45
FLT output, 26
front panel, 19, 35
 annunciators, 36
 connections, 23
 controls and indicators, 35
 keys, 36
FS, 38, 43
FS status, 26
function keys, 38
 ▲, 38
 Cal, 40
 Current, 40
 immediate action, 38
 Input, 39
 Meter, 39

Index

OCP, 38
Output, 40
Output On/Off, 38
OV, 40
Prot Clear, 38
Protect, 40
Voltage, 40
fuses, 23

—G—

ground, earth, 18
guide, programming, 17
guide, user's, 17

—H—

history, 6
 GPIB, 46
 address, 46
 connections, 28
 interface, 28

—I—

INH, 45
INH input, 26
input
 connections, 23
 power, 18
inspection, 21

—L—

line fuse
 replacing, 34
line voltage conversion, 69
load line, 20
load voltage drops, 24
location, 22

—M—

making measurements, 43
manuals, 21
measurement ranges, 43
multiple loads, 24

—N—

non-volatile memory
 clearing, 47
 storing, 37, 40

—O—

OC, 43

operating features, 19
option 760, 46
options, 18
OT, 43
output
 characteristic, 20
 connections, 23
 connector, 21
 control keys, 40
 current setting, 42
 enable, 42
 rating, 20
 voltage setting, 42
output relay, 46
OV, 43
OVL, 34, 43
OVP
 capacitor discharge limit, 26
 circuit, 26

—P—

power cord, 21, 23
power receptacle, 18
preliminary checkout, 31
print date, 6
protection
 FS, 43
 OC, 43
 OT, 43
 OV, 43
 RI, 43

—Q—

query protection, 43

—R—

rack mount kit, 18
rack mounting, 22
rear panel
 connections, 26, 28, 29
recalling operating states, 47
remote programming, 19
remote sensing, 25
 stability, 26
repacking, 21
RI, 43
 signal, 26
RIDFI, 45
RS-232, 46
 connections, 29
 interface, 29

—S—

safety class, 18
safety warning, 18
saving operating states, 47

- selftest errors, 34
- sense connections, 25
- service guide, 18
- setting voltage/current, 42
- shift annunciator, 31
- shift key, 31
- shorting switch, 27
- specifications, 49
- stability with remote sensing, 26
- supplemental characteristics, 50
- system errors, 65
- system keys, 37
 - Address, 37
 - Error, 37
 - Interface, 37
 - Local, 37
 - RCL, 37
 - Save, 37
 - Shift, 37

—T—

- turn-on checkout, 31, 55

—V—

- verification
 - current measurement accuracy, 55
 - current programming, 55
 - equipment, 53
 - setup, 53
 - test record, 57
 - voltage measurement accuracy, 55
 - voltage programming, 55
- verification tests, 31

—W—

- warranty, 2
- wire
 - current ratings, 23
- wiring considerations, 23

Agilent Sales and Support Office

For more information about Agilent Technologies test and measurement products, applications, services, and for a current sales office listing, visit our web site: <http://www.agilent.com/find/tmdir>

You can also contact one of the following centers and ask for a test and measurement sales representative.

United States:

Agilent Technologies
Test and Measurement Call Center
P.O. Box 4026
Englewood, CO 80155-4026
(tel) 1 800 452 4844

Latin America:

Agilent Technologies
Latin American Region Headquarters
5200 Blue Lagoon Drive, Suite #950
Miami, Florida 33126
U.S.A.
(tel) (305) 267 4245
(fax) (305) 267 4286

Canada:

Agilent Technologies Canada Inc.
5150 Spectrum Way
Mississauga, Ontario
L4W 5G1
(tel) 1 877 894 4414

Australia/New Zealand:

Agilent Technologies Australia Pty Ltd
347 Burwood Highway
Forest Hill, Victoria 3131
(tel) 1-800 629 485 (Australia)
(fax) (61 3) 9272 0749
(tel) 0 800 738 378 (New Zealand)
(fax) (64 4) 802 6881

Europe:

Agilent Technologies
Test & Measurement European Marketing Organisation
P.O. Box 999
1180 AZ Amstelveen
The Netherlands
(tel) (31 20) 547 9999

Asia Pacific:

Agilent Technologies
24/F, Cityplaza One, 1111 King's Road,
Taikoo Shing, Hong Kong
tel: (852)-3197-7777
fax: (852)-2506-9284

Japan:

Agilent Technologies Japan Ltd.
Measurement Assistance Center
9-1, Takakura-Cho, Hachioji-Shi,
Tokyo 192-8510, Japan
(tel) (81) 426 56 7832
(fax) (81) 426 56 7840

Technical data is subject to change.

Manual Updates

The following updates have been made to this manual since the November 1997 printing indicated on the Printing History page.

7/8/99

The Isink rating referred to on page 20 has been corrected. Additional information about CV mode operation has also been added to this page.

Notes have been added to Table A-1 for the Ripple and Noise specifications as well as the DC Measurement Accuracy Voltage specification.

A note has been added to table A-2 for the OVP Accuracy characteristic, and the Isolation to Ground characteristic has been corrected.

Steps 19 and 20 on page 61 under Low Range Current Measurement Calibration have been switched.

1/7/00

All references to HP have been changed to Agilent.

All references to HP-IB have been changed to GPIB.

A note about magnetic fields has been added to page 22.

On page 49 the model reference for note 3 has been corrected.

2/21/01

Fuse part numbers on page 21 and 68 have been corrected.

A note has been added to Table A-1 for the Programming Accuracy specification.